

AW-NM459

IEEE 802.11 b/g/n Wireless LAN and Bluetooth Module

Datasheet

Rev. A

DF

(For Standard)

Features

Wi-Fi

- Single band 2.4 GHz 802.11 b/g/n
- SDIO v2.0, including DS and HS modes
- Security—WEP, WPA/WPA2 (personal), AES (HW), TKIP (HW), CKIP (SW), WMM/WMM-PS/WMM-SA
- Data Rate up to 72.2Mbps

Bluetooth

- Supports extended Synchronous Connections (eSCO), for enhanced voice quality by allowing for retransmission of dropped packets
- Adaptive Frequency Hopping (AFH) for reducing radio frequency interference
- Maximum UART baud rates up to 4 Mbps
- Supports 5.0's LE Secure Connections

- Fully supports Bluetooth Core Specification version 5.1 + (Enhanced Data Rate) EDR features:
 - Adaptive Frequency Hopping (AFH)
 - Quality of Service (QoS)
 - Extended Synchronous Connections (eSCO) — Voice Connections
 - Fast Connect (interlaced page and inquiry scans)
 - Secure Simple Pairing (SSP)
 - Sniff Subrating (SSR)
 - Encryption Pause Resume (EPR)
 - Extended Inquiry Response (EIR)
 - Link Supervision Timeout (LST)
- Interface support – Host Controller Interface (HCI) using a high-speed UART interface and PCM for audio data

Revision History

Document NO: R2-2459-DST-01

Version	Revision Date	DCN NO.	Description	Initials	Approved
A	2020/7/6	DCN016921	● Initial Version	Steven Jian	Chihhao Liao

Table of Contents

Revision History.....	3
Table of Contents.....	4
1. Introduction	5
1.1 Product Overview	5
1.2 Block Diagram.....	6
1.3 Specifications Table	7
1.3.1 General	7
1.3.2 WLAN	7
1.3.3 Bluetooth.....	9
1.3.4 Operating Conditions.....	9
2. Pin Definition	10
2.1 Pin Map.....	10
2.2 Pin Table.....	11
3. Electrical Characteristics	13
3.1 Absolute Maximum Ratings	13
3.2 Recommended Operating Conditions	13
3.3 Digital IO Pin DC Characteristics.....	13
3.4 Host Interface.....	15
3.4.1 SDIO	15
3.4.2 UART Interface	17
3.4.3 PCM Interface Timing.....	18
3.5 Power up Timing Sequence	21
3.6 Power Consumption*	23
3.6.1 WLAN	23
3.6.2 Bluetooth.....	23
4. Mechanical Information	24
4.1 Mechanical Drawing	24
5. Packaging Information	25

1. Introduction

1.1 Product Overview

AzureWave Technologies, Inc. introduces the advanced IEEE 802.11 b/g/n WLAN and Bluetooth combo module - AW-NM459. The module is targeted to mobile and embedded devices which need small footprint package, low power consumption, and multiple OS support. The module supports 2.4GHz IEEE 802.11n MAC/baseband/radio, and Bluetooth 5.1 functionality. It also features an integrated Power Management Unit (PMU), Power Amplifiers (PAs), and a Low Noise Amplifier (LNA) to address the needs of mobile devices that require minimal power consumption and compact size. By using AW-NM459, the customers can easily enable the Wi-Fi and BT embedded applications with the benefits of high design flexibility, short development cycle, and quick time-to-market. Specified in the IEEE 802.11 standard minimize the system power requirements by using AW-NM459. In addition to the support of WPA/WPA2 (personal) and WEP encryption, the AW-NM459 also supports the IEEE 802.11i security standard through AES and TKIP acceleration hardware for faster data encryption. For the video, voice and multimedia applications the AW-NM459 support 802.11e Quality of Service (QoS). The host interface is SDIO v2.0 interface.

For Bluetooth operation, the AW-NM459 is Bluetooth 5.1 compliant. The Bluetooth transmitter also features a Class 1 power amplifier. The AW-NM459 supports extended Synchronous Connections (eSCO), for enhanced voice quality by allowing for retransmission of dropped packets, and Adaptive Frequency Hopping (AFH) for reducing radio frequency interference. It also incorporates all Bluetooth 5.1 features including Secure Simple Pairing, Sniff Subrating, and Encryption Pause and Resume. An independent, high-speed UART is provided for the Bluetooth host interface. The Bluetooth subsystem presents a standard Host Controller Interface (HCI) via a high speed UART and PCM for audio.

1.2 Block Diagram

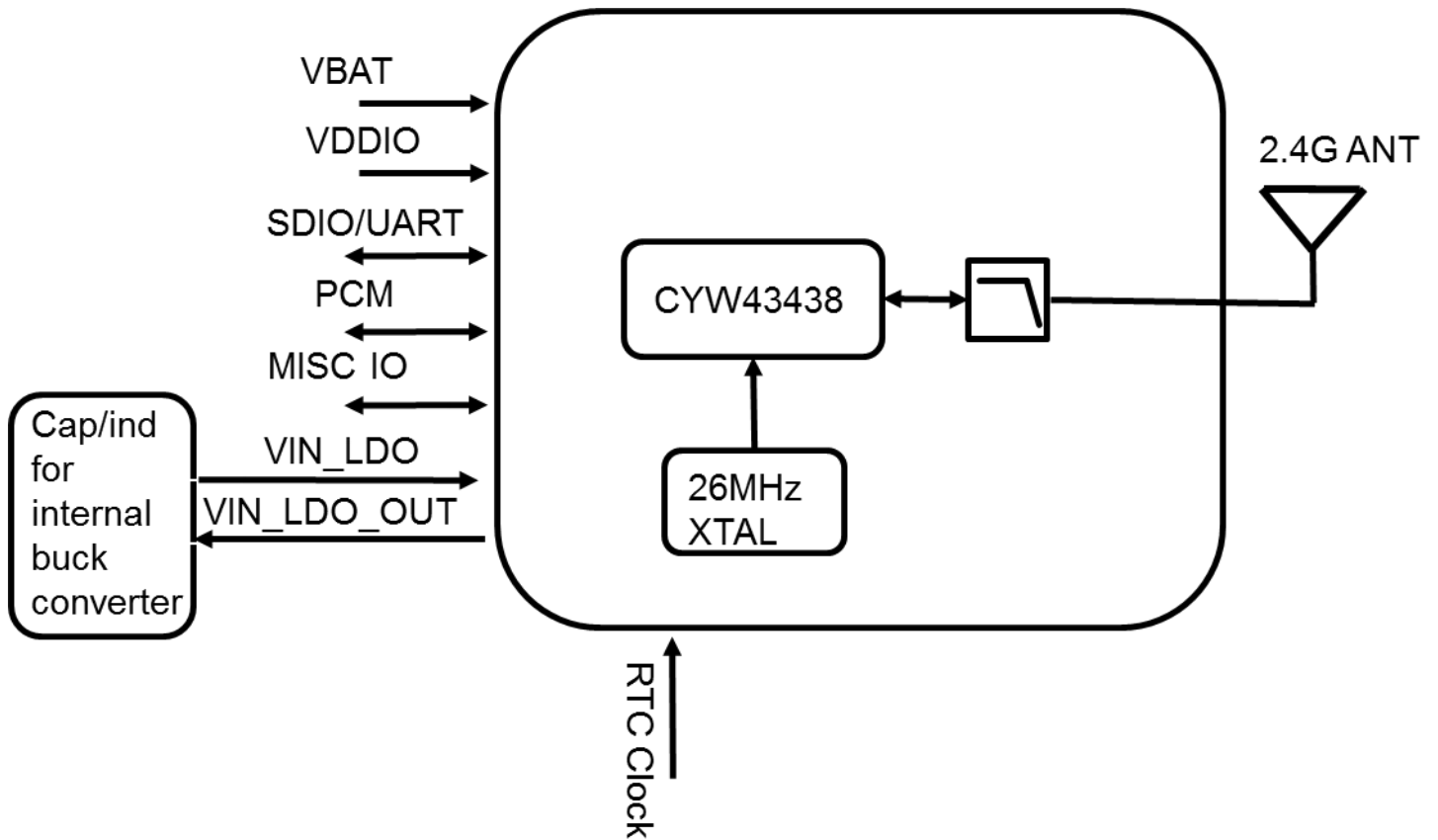

1.3 Specifications Table

1.3.1 General

Features	Description
Product Description	IEEE 802.11 b/g/n Wireless LAN and Bluetooth Module
Major Chipset	Cypress CYW43438_A1
Host Interface	WLAN: SDIO v2.0 Bluetooth: UART
Dimension	7mm(L) x 7mm(W) x 1.5 mm(H)
Package	53 pin LGA Module
Antenna	2.4G Ant: Wi-Fi/BT
Weight	0.15g

1.3.2 WLAN

Features	Description
WLAN Standard	IEEE 802.11 b/g/n, Wi-Fi compliant
WLAN VID/PID	N/A
WLAN SVID/SPID	N/A
Frequency Range	WLAN: 2.4 GHz
Modulation	DSSS, OFDM, BPSK(9/6Mbps), QPSK(18/12Mbps), DBPSK(1Mbps), DQPSK(2Mbps), CCK(11/5.5Mbps), 16-QAM(36/24Mbps), 64-QAM (72.2/54/48Mbps)
Number of Channels	802.11b: USA, Canada and Taiwan – 1 ~ 11 Most European Countries – 1 ~ 13 Japan – 1 ~ 14 802.11g: USA and Canada – 1 ~ 11 Most European Countries – 1 ~ 13 802.11n: USA and Canada – 1 ~ 11

	Most European Countries – 1 ~ 13				
Output Power	2.4G				
		Min	Typ	Max	Unit
	11b (1Mbps) @EVM < 35%	17	19	21	dBm
	11b (11Mbps) @EVM < 35%	17	19	21	dBm
	11g (6Mbps) @EVM ≤ -5 dB	16	18	20	dBm
	11g (54Mbps) @EVM ≤ -25 dB	15	17	19	dBm
	11n (HT20 MCS0) @ EVM ≤ -5 dB	16	18	20	dBm
	11n (HT20 MCS7) @EVM ≤ -27 dB	14.5	16.5	18.5	dBm
Receiver Sensitivity	2.4G				
		Min	Typ	Max	Unit
	11b (1Mbps)		-96.5	-93	dBm
	11g (6Mbps)		-91	-87	dBm
	11b (11Mbps)		-89.5	-85	dBm
	11g (54Mbps)		-76	-71	dBm
	11n (HT20 MCS0)		-91.5	-86	dBm
11n (HT20 MCS7)		-73.5	-69	dBm	
Data Rate	802.11b: 1, 2, 5.5, 11Mbps 802.11g: 6, 9, 12, 18, 24, 36, 48, 54Mbps 802.11n:MCS 0~7 HT20				
Security	<ul style="list-style-type: none"> ◆ WPA™- and WPA2™- (Personal) support for powerful encryption and authentication ◆ AES and TKIP acceleration hardware for faster data encryption and 802.11i compatibility ◆ Cisco® Compatible Extension- (CCX, CCX 2.0, CCX 3.0, CCX 4.0, CCX5.0) certified ◆ Wi-Fi Protected Setup (WPS) ◆ WEP ◆ WMM / WMM-SA ◆ CKIP(Software) 				

1.3.3 Bluetooth

Features	Description																				
Bluetooth Standard	Bluetooth 2.1+Enhanced Data Rate (EDR) /Core Specification 5.1																				
Bluetooth VID/PID	N/A																				
Frequency Range	2400~2483.5MHz																				
Modulation	GFSK (1Mbps), $\pi/4$ DQPSK (2Mbps) and 8DPSK (3Mbps)																				
Output Power	Basic Rate : 8.5dBm +/- 3dBm (Max Settings) BLE:8.5dBm+/-3dBm																				
Receiver Sensitivity	<table border="1"> <thead> <tr> <th></th> <th>Min</th> <th>Typ</th> <th>Max</th> <th>Unit</th> </tr> </thead> <tbody> <tr> <td>DH5</td> <td></td> <td>-93</td> <td>-82</td> <td>dBm</td> </tr> <tr> <td>2DH5</td> <td></td> <td>-95</td> <td>-84</td> <td>dBm</td> </tr> <tr> <td>3DH5</td> <td></td> <td>-88</td> <td>-78</td> <td>dBm</td> </tr> </tbody> </table>		Min	Typ	Max	Unit	DH5		-93	-82	dBm	2DH5		-95	-84	dBm	3DH5		-88	-78	dBm
		Min	Typ	Max	Unit																
	DH5		-93	-82	dBm																
	2DH5		-95	-84	dBm																
3DH5		-88	-78	dBm																	

1.3.4 Operating Conditions

Features	Description
Operating Conditions	
Voltage	WIFI/BT VBAT:3.2V~4.8V (3.6V Typical)
Operating Temperature	-30~85 °C (Optimal RF performance guarantee -20~85 °C)
Operating Humidity	less than 85% R.H.
Storage Temperature	-40~85 °C
Storage Humidity	less than 60% R.H.
ESD Protection	
Human Body Model	± 1 KV
Charged Device Model	± 300 V

2. Pin Definition

2.1 Pin Map

AW-NM459 Top View Pin Map

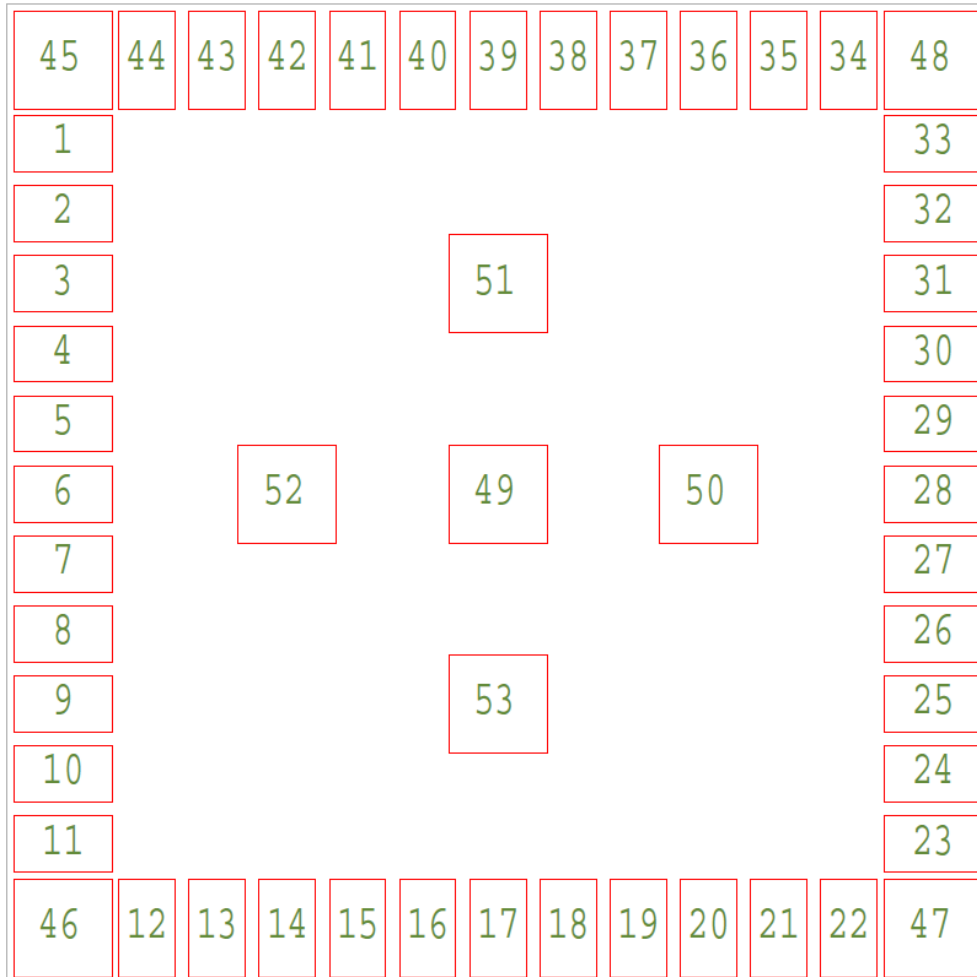

2.2 Pin Table

Pin No	Definition	Basic Description	Voltage	Type
1	WL_BT_ANT	RF I/O port		RF
2	GND_2	Ground		GND
3	BT_WAKE	HOST wake-up Bluetooth device	VDDIO	I
4	BT_HOST_WAKE	Bluetooth device to wake-up HOST	VDDIO	O
5	BT_REG_ON	Bluetooth device enable/disable pin. Used by PMU to power up or power down the internal regulators used by the Bluetooth/FM section. Also, when deasserted, this pin holds the Bluetooth/FM section in reset. This pin has an internal 200 k pull-down resistor that is enabled by default. It can be disabled through programming.	VDDIO	I
6	NC_6	Floating (Don't connected to ground)		Floating
7	NC_7	Floating (Don't connected to ground)		Floating
8	NC_8	Floating (Don't connected to ground)		Floating
9	GND_9	Ground		GND
10	NC_10	Floating (Don't connected to ground)		Floating
11	NC_11	Floating (Don't connected to ground)		Floating
12	NC_12	Floating (Don't connected to ground)		Floating
13	NC_13	Floating (Don't connected to ground)		Floating
14	GND_14	Ground		GND
15	NC_15	Floating (Don't connected to ground)		Floating
16	NC_16	Floating (Don't connected to ground)		Floating
17	WL_GPIO2	WL_GPIO2, Can be programmed as antenna diversity control pin	VDDIO	I/O
18	WL_GPIO1	WL_GPIO1	VDDIO	I/O
19	WL_HOST_WAKE	WLAN device to wake-up HOST	VDDIO	O
20	WL_REG_ON	WLAN device enable/disable pin. Used by PMU to power up or power down the internal regulators used by the WLAN section. Also, when deasserted, this pin holds the WLAN section in reset. This pin has an internal 200 k pull-down resistor that is enabled by default. It can be disabled through programming	VDDIO	I
21	GND_21	Ground		GND
22	NC_22	Floating (Don't connected to ground)		Floating
23	SDIO_DATA_CMD	WLAN SDIO command line	VDDIO	I/O
24	SDIO_DATA_CLK	WLAN SDIO clock line	VDDIO	I/O
25	SDIO_DATA_2	WLAN SDIO data line 2	VDDIO	I/O

26	SDIO_DATA_0	WLAN SDIO data line 0	VDDIO	I/O
27	SDIO_DATA_3	WLAN SDIO data line 3	VDDIO	I/O
28	SDIO_DATA_1	WLAN SDIO data line 1	VDDIO	I/O
29	GND_29	Ground		GND
30	VDDIO	1.8V-3.3V VDDIO supply for WLAN and BT	VDDIO	P
31	LPO	External Low Power Clock input (32.768KHz)		I
32	VIN_LDO	Internal Buck voltage generation pin	1.4V	P
33	VBAT	Main power voltage source input	VBAT	P
34	VIN_LDO_OUT	Internal Buck voltage generation pin	1.4V	P
35	GND_35	Ground		GND
36	PCM_CLK	PCM clock	VDDIO	I/O
37	PCM_SYNC	PCM sync signal	VDDIO	I/O
38	PCM_OUT	PCM Data output	VDDIO	O
39	PCM_IN	PCM data input	VDDIO	I
40	UART_TXD	Bluetooth UART_TXD	VDDIO	O
41	UART_RXD	Bluetooth UART_RXD	VDDIO	I
42	UART_CTS_N	Bluetooth UART_CTS_N	VDDIO	I
43	UART_RTS_N	Bluetooth UART_RTS_N	VDDIO	O
44	GND_44	Ground		GND
45	GND_45	Ground		GND
46	GND_46	Ground		GND
47	GND_47	Ground		GND
48	GND_48	Ground		GND
49	GND_49	Ground		GND
50	GND_50	Ground		GND
51	GND_51	Ground		GND
52	GND_52	Ground		GND
53	GND_53	Ground		GND

3. Electrical Characteristics

3.1 Absolute Maximum Ratings

Symbol	Parameter	Minimum	Typical	Maximum	Unit
VBAT	Power supply for Internal Regulators	-0.5		6	V
VDDIO	DC supply voltage for digital I/O	-0.5		3.9	V

3.2 Recommended Operating Conditions

Symbol	Parameter	Minimum	Typical	Maximum	Unit
VBAT	Power supply for Internal Regulators	3*	3.6	4.8*	V
VDDIO	DC supply voltage for digital I/O	1.71		3.63	V

*Optimal RF performance is guaranteed only for $3.2V < VBAT < 4.8V$

3.3 Digital IO Pin DC Characteristics

Symbol	Parameter	Minimum	Typical	Maximum	Unit
For SDIO Interface VDDIO =1.8V					
VIH	Input high voltage	1.27	-	-	V
VIL	Input low voltage	-	-	0.58	V
VOH	Output High Voltage @ 2mA	1.4	-	-	V
VOL	Output Low Voltage @ 2mA	-	-	0.45	V
For SDIO Interface VDDIO =3.3V					
VIH	Input high voltage	2.06	-	-	V
VIL	Input low voltage	-	-	0.82	V

VOH	Output High Voltage @ 2mA	2.47	-	-	V
VOL	Output Low Voltage @ 2mA	-	-	0.41	V
Other Digital Interface VDDIO=1.8V					
VIH	Input high voltage	1.17	-	-	V
VIL	Input low voltage	-	-	0.63	V
VOH	Output High Voltage @ 2mA	1.35	-	-	V
VOL	Output Low Voltage @ 2mA	-	-	0.45	V
Other Digital Interface VDDIO=3.3V					
VIH	Input high voltage	1.17	-	-	V
VIL	Input low voltage	-	-	0.8	V
VOH	Output High Voltage @ 2mA	1.35	-	-	V
VOL	Output Low Voltage @ 2mA	-	-	0.4	V

3.4 Host Interface

3.4.1 SDIO

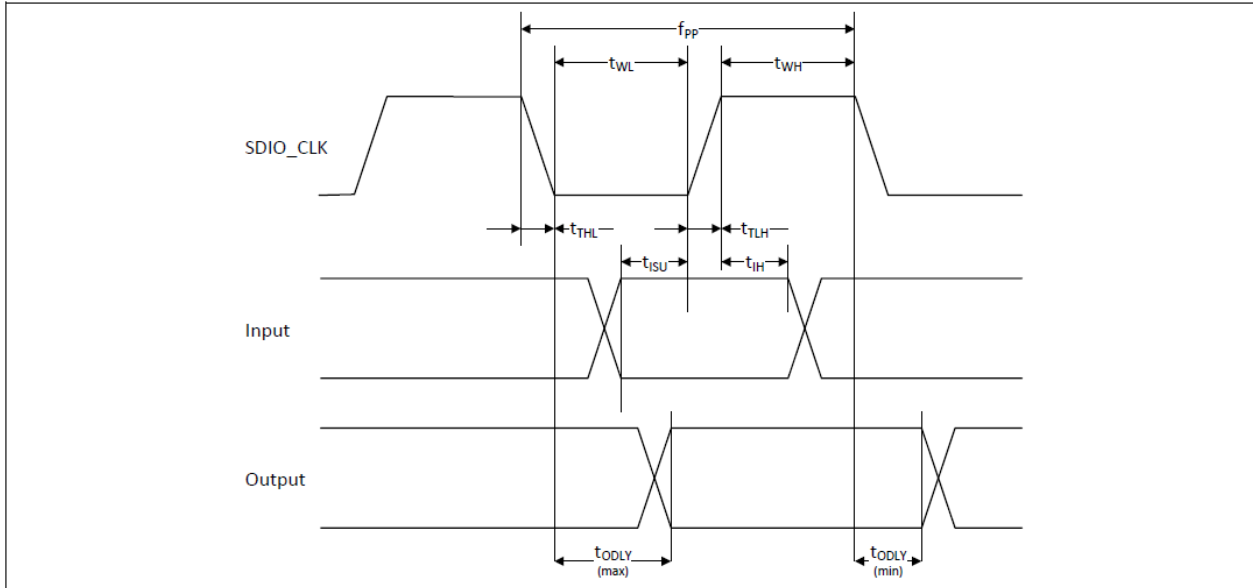

SDIO Bus Timing (Default Mode)

Parameter	Symbol	Minimum	Typical	Maximum	Unit
SDIO CLK (All values are referred to minimum VIH and maximum VIL*)					
Frequency – Data Transfer mode	fPP	0	–	25	MHz
Frequency – Identification mode	fOD	0	–	400	kHz
Clock low time	tWL	10	–	–	ns
Clock high time	tWH	10	–	–	ns
Clock rise time	tTLH	–	–	10	ns
Clock low time	tTHL	–	–	10	ns
Inputs: CMD, DAT (referenced to CLK)					
Input setup time	tISU	5	–	–	ns
Input hold time	tIH	5	–	–	ns
Outputs: CMD, DAT (referenced to CLK)					
Output delay time – Data Transfer mode	tODLY	0	–	14	ns
Output delay time – Identification mode	tODLY	0	–	50	ns

SDIO Bus Timing Parameters (Default Mode)

* min (VIH) = 0.7 × VDDIO and max (VIL) = 0.2 × VDDIO

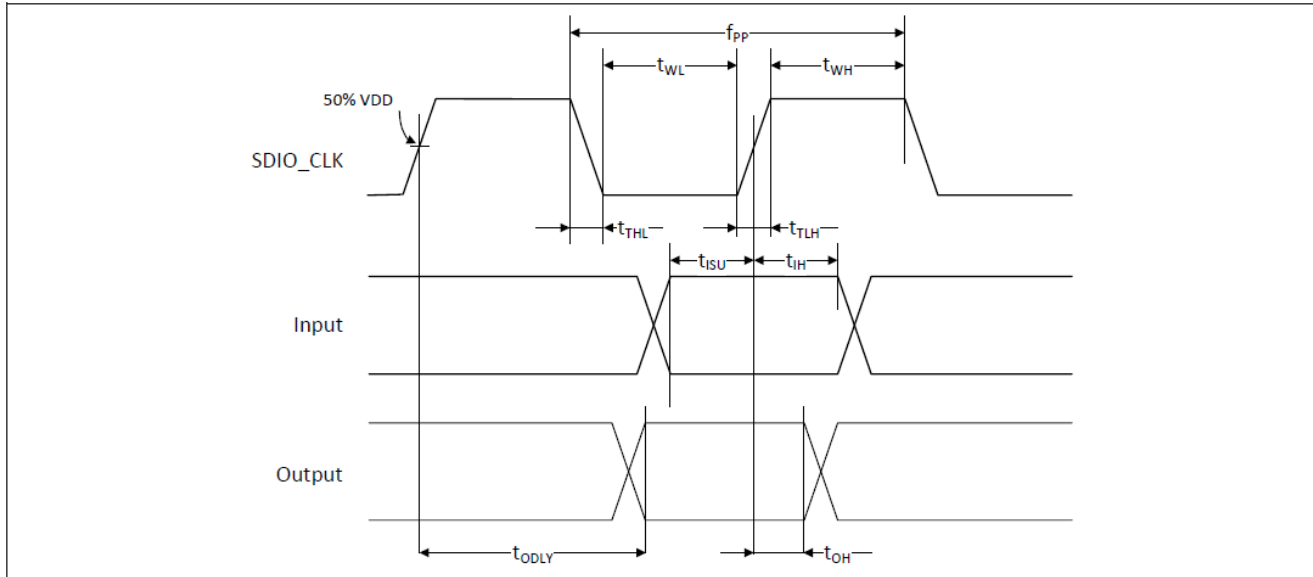

SDIO Bus Timing (High-Speed Mode)

Parameter	Symbol	Minimum	Typical	Maximum	Unit
SDIO CLK (all values are referred to minimum VIH and maximum VIL*)					
Frequency – Data Transfer Mode	f _{PP}	0	–	50	MHz
Frequency – Identification Mode	f _{OD}	0	–	400	kHz
Clock low time	t _{WL}	7	–	–	ns
Clock high time	t _{WH}	7	–	–	ns
Clock rise time	t _{TLH}	–	–	3	ns
Clock low time	t _{THL}	–	–	3	ns
Inputs: CMD, DAT (referenced to CLK)					
Input setup Time	t _{ISU}	6	–	–	ns
Input hold Time	t _{IH}	2	–	–	ns
Outputs: CMD, DAT (referenced to CLK)					
Output delay time – Data Transfer Mode	t _{ODLY}	–	–	14	ns
Output hold time	t _{OH}	2.5	–	–	ns
Total system capacitance (each line)	CL	–	–	40	pF

SDIO Bus Timing a Parameters (High-Speed Mode)

* min (VIH) = 0.7 × VDDIO and max (VIL) = 0.2 × VDDIO

3.4.2 UART Interface

The AW-NM459 includes a single UART for Bluetooth. The UART is a standard 4-wire interface (RX, TX, RTS, and CTS) with adjustable baud rates from 9600 bps to 4.0 Mbps. The interface features an automatic baud rate detection capability that returns a baud rate selection. Alternatively, the baud rate may be selected through a vendor-specific UART HCI command.

UART has a 1040-byte receive FIFO and a 1040-byte transmit FIFO to support EDR. Access to the FIFOs is conducted through the AHB interface through either DMA or the CPU. The UART supports the Bluetooth 5.1 UART HCI specification: H4, a custom Extended H4, and H5. The default baud rate is 115.2 Kbaud.

The UART supports the 3-wire H5 UART transport, as described in the Bluetooth specification (“Three-wire UART Transport Layer”). Compared to H4, the H5 UART transport reduces the number of signal lines required by eliminating the CTS and RTS signals.

The AW-NM459 UART can perform XON/XOFF flow control and includes hardware support for the Serial Line Input Protocol (SLIP). It can also perform wake-on activity. For example, activity on the RX or CTS inputs can wake the chip from a sleep state.

Normally, the UART baud rate is set by a configuration record downloaded after device reset, or by automatic baud rate detection, and the host does not need to adjust the baud rate. Support for changing the baud rate during normal HCI UART operation is included through a vendor-specific command that allows the host to adjust the contents of the baud rate registers. The AW-NM459 UARTs operate correctly with the host UART as long as the combined baud rate error of the two devices is within $\pm 2\%$.

UART Interface Signals

PIN No.	Name	Description	Type
40	UART_TXD	Bluetooth UART Serial Output. Serial data output for the HCI UART Interface	O
41	UART_RXD	Bluetooth UART Series Input. Serial data input for the HCI UART Interface	I
43	UART_RTS_N	Bluetooth UART Request-to-Send. Active-low request-to-send signal for the HCI UART interface	O
42	UART_CTS_N	Bluetooth UART Clear-to-Send. Active-low clear-to-send signal for the HCI UART interface.	I

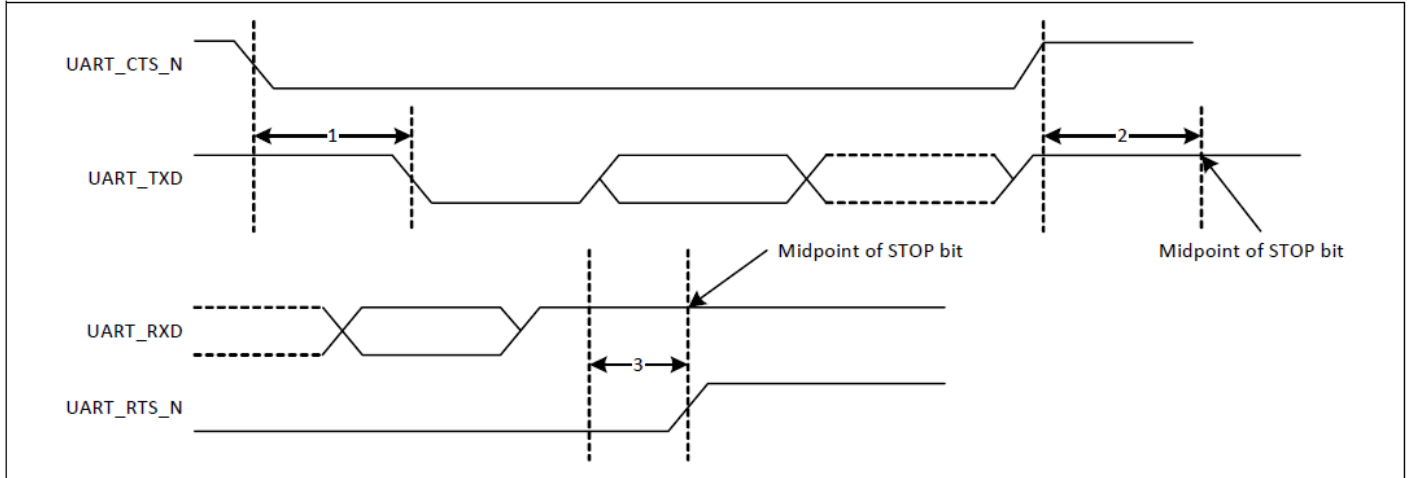

UART Timing

	Reference Characteristics	Minimum	Typical	Maximum	Unit
1	Delay time, UART_CTS_N low to UART_TXD valid	—	—	1.5	Bit periods
2	Setup time, UART_CTS_N high before midpoint of stop bit	—	—	0.5	Bit periods
3	Delay time, midpoint of stop bit to UART_RTS_N high	—	—	0.5	Bit periods

UART Timing Specifications

3.4.3 PCM Interface Timing

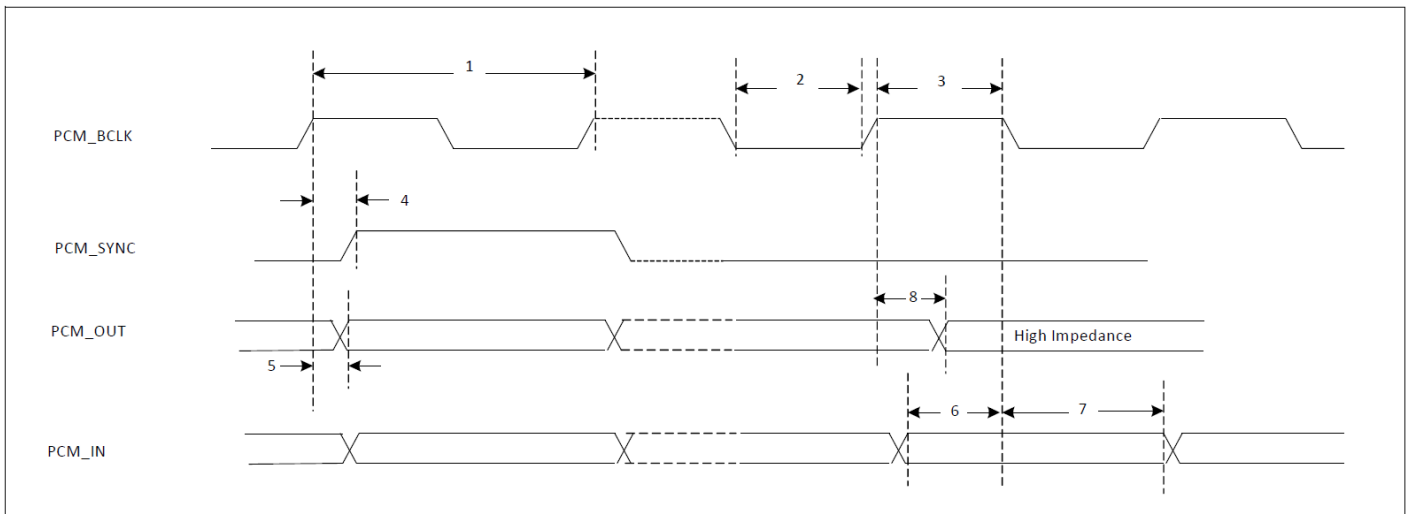

PCM Timing Diagram (Short Frame Sync, Master Mode)

	Reference Characteristics	Minimum	Typical	Maximum	Unit
1	PCM bit clock frequency			12	MHz
2	PCM bit clock low	41			ns
3	PCM bit clock high	41			ns
4	PCM_SYNC delay	0		25	ns
5	PCM_OUT delay	0		25	ns
6	PCM_IN setup	8			ns
7	PCM_IN hold	8			ns
8	Delay from rising edge of PCM_BCLK during last bit period to PCM_OUT becoming high impedance	0		25	ns

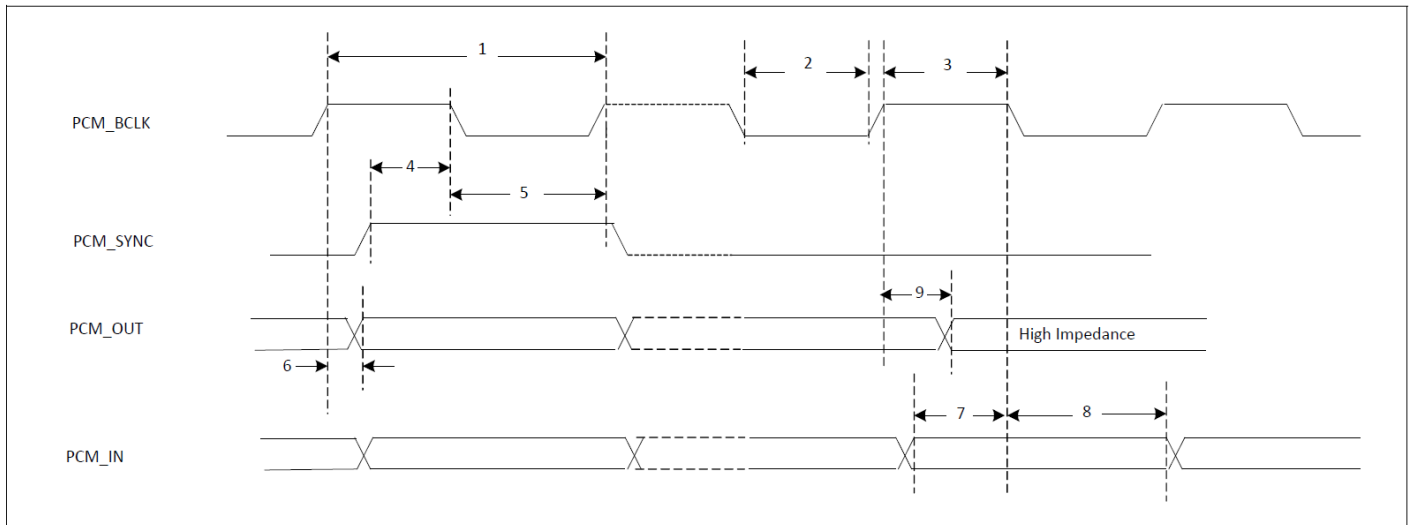

PCM Timing Diagram (Short Frame Sync, Slave Mode)

	Reference Characteristics	Minimum	Typical	Maximum	Unit
1	PCM bit clock frequency			12	MHz
2	PCM bit clock low	41			ns
3	PCM bit clock high	41			ns
4	PCM_SYNC setup	8			ns
5	PCM_SYNC hold	8			ns
6	PCM_OUT delay	0		25	ns
7	PCM_IN setup	8			ns
8	PCM_IN hold	8			ns
9	Delay from rising edge of PCM_BCLK during last bit period to PCM_OUT becoming high impedance	0		25	ns

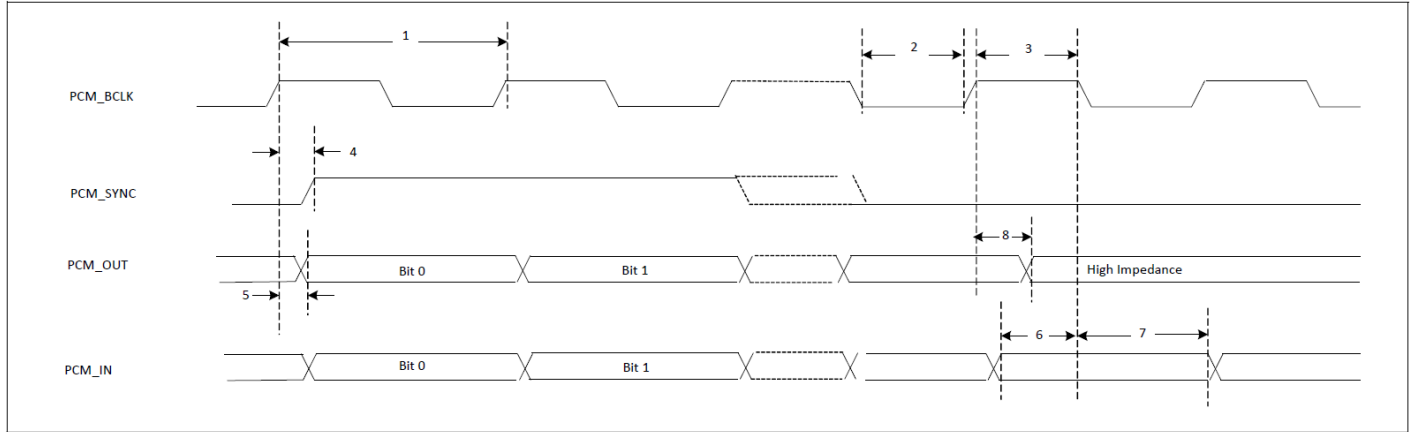

PCM Timing Diagram (Long Frame Sync, Master Mode)

	Reference Characteristics	Minimum	Typical	Maximum	Unit
1	PCM bit clock frequency			12	MHz
2	PCM bit clock low	41			ns
3	PCM bit clock high	41			ns
4	PCM_SYNC delay	0		25	ns
5	PCM_OUT delay	0		25	ns
6	PCM_IN setup	8			ns
7	PCM_IN hold	8			ns
8	Delay from rising edge of PCM_BCLK during last bit period to PCM_OUT becoming high impedance	0		25	ns

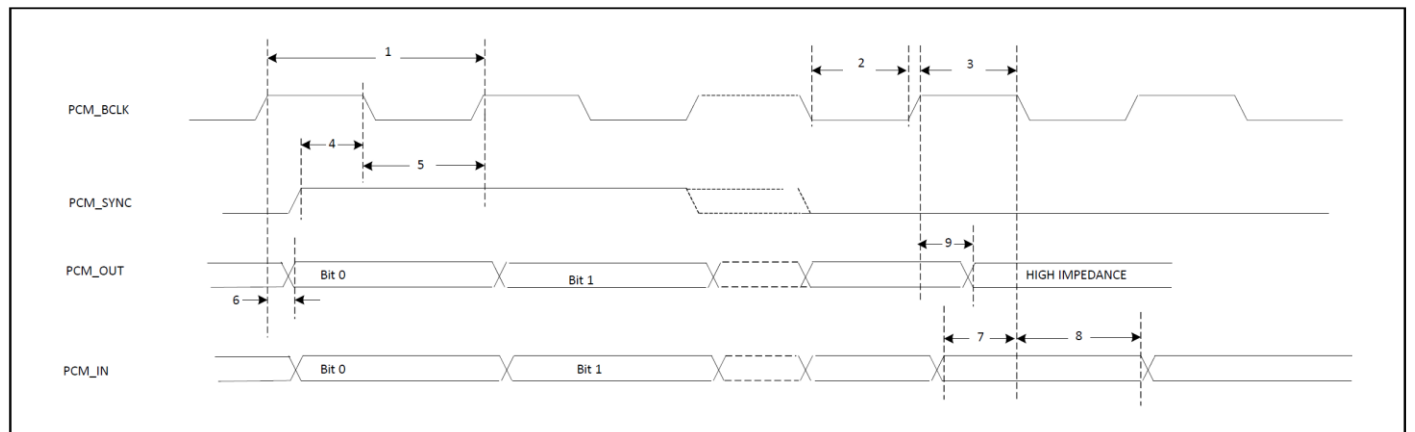

PCM Timing Diagram (Long Frame Sync, Slave Mode)

	Reference Characteristics	Minimum	Typical	Maximum	Unit
1	PCM bit clock frequency			12	MHz
2	PCM bit clock low	41			ns
3	PCM bit clock high	41			ns
4	PCM_SYNC setup	8			ns
5	PCM_SYNC hold	8			ns
6	PCM_OUT delay	0		25	ns
7	PCM_IN setup	8			ns
8	PCM_IN hold	8			ns
9	Delay from rising edge of PCM_BCLK during last bit period to PCM_OUT becoming high impedance	0		25	ns

3.5 Power up Timing Sequence

WLAN = ON, Bluetooth = ON

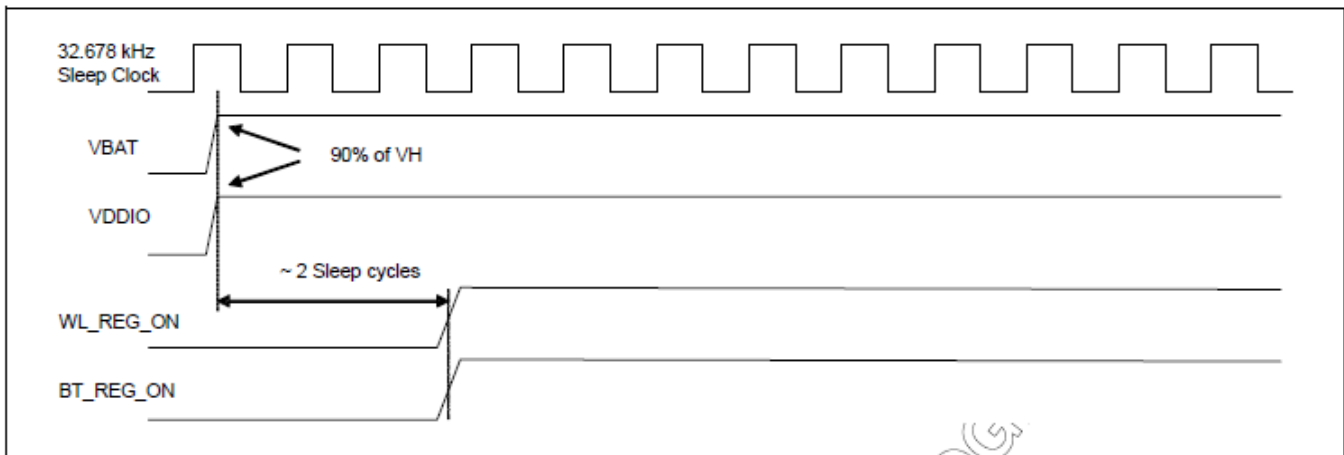

WLAN = OFF, Bluetooth = OFF

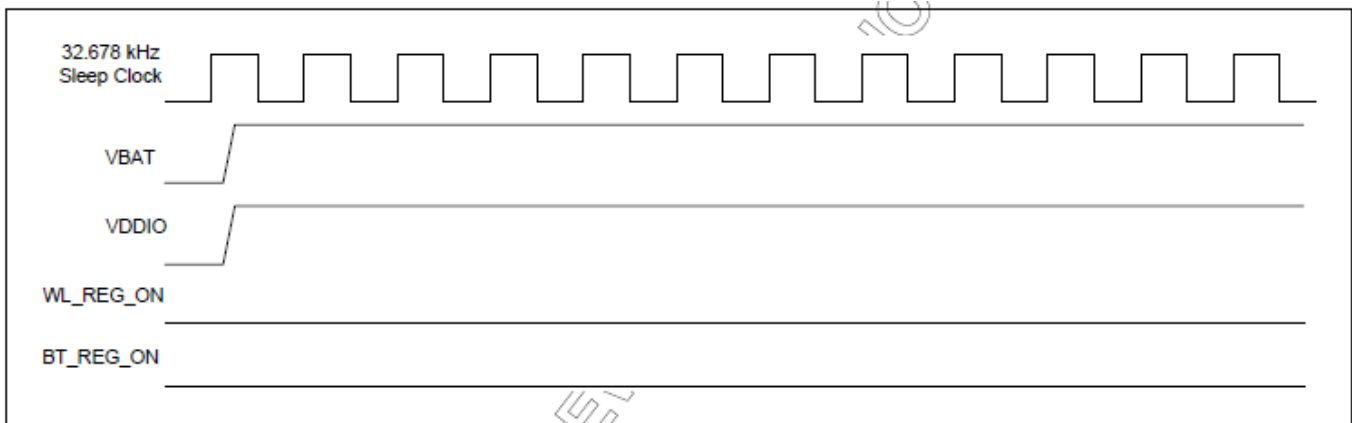

WLAN = ON, Bluetooth = OFF

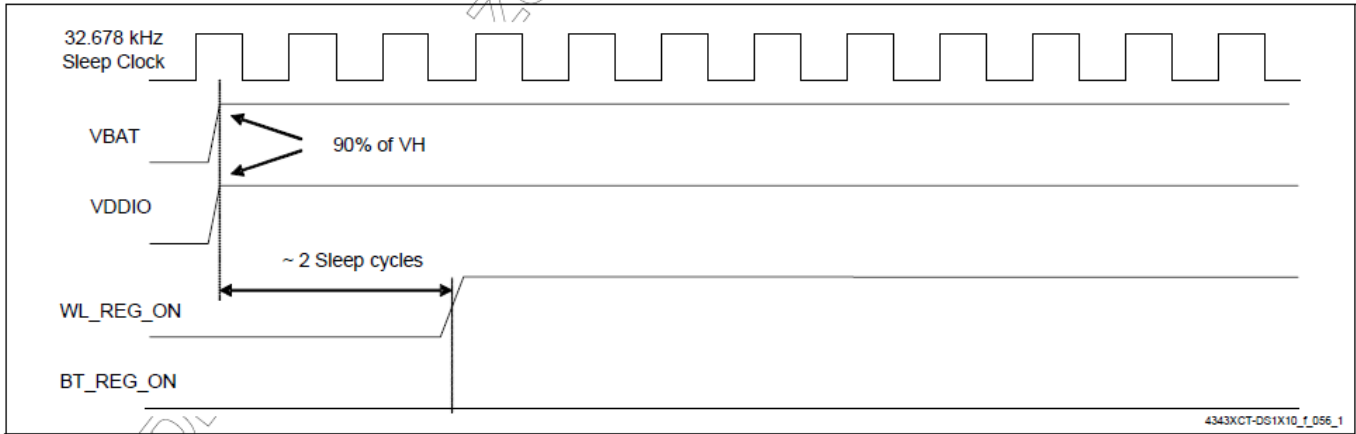

WLAN = OFF, Bluetooth = ON

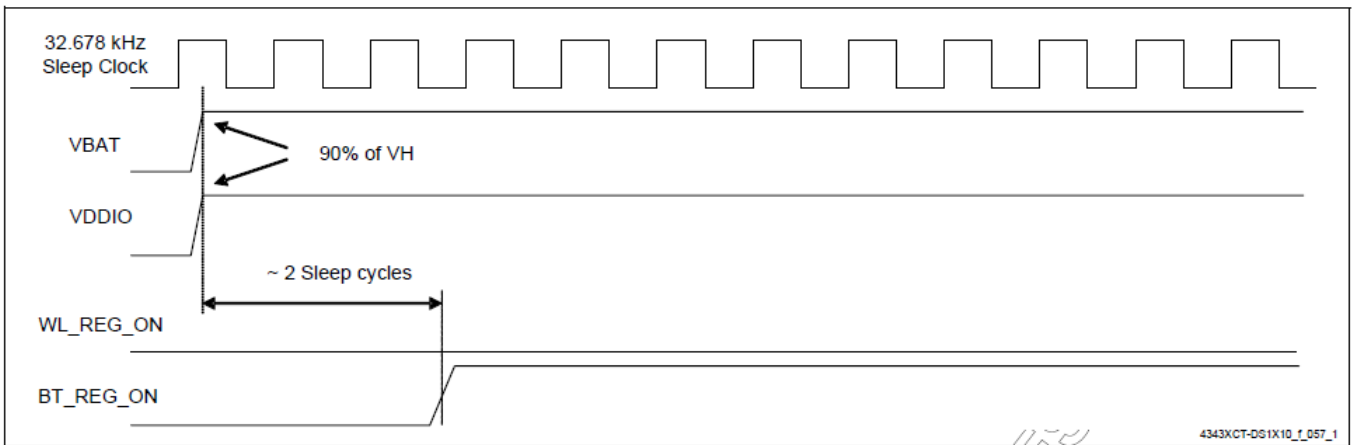

3.6 Power Consumption*

3.6.1 WLAN

TBD

3.6.2 Bluetooth

TBD

4. Mechanical Information

4.1 Mechanical Drawing

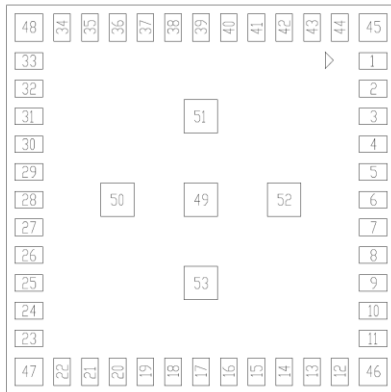

PIN DEFINED (BOTTOM VIEW)

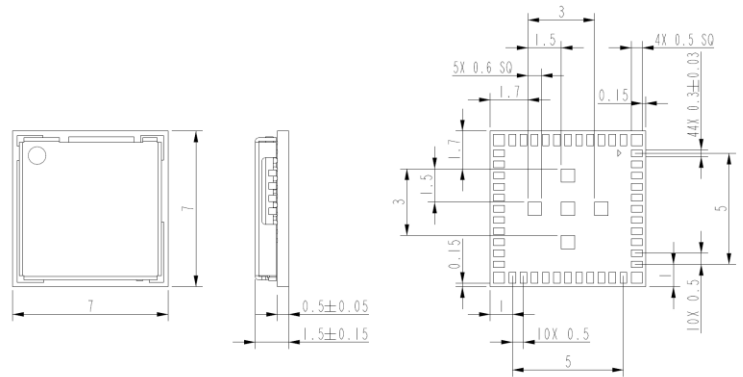
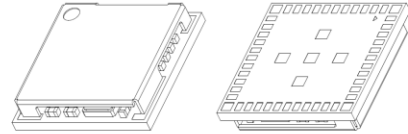

TOLERANCES UNLESS OTHERWISE SPECIFIED: ±0.1mm

5. Packaging Information

5.1



5.2

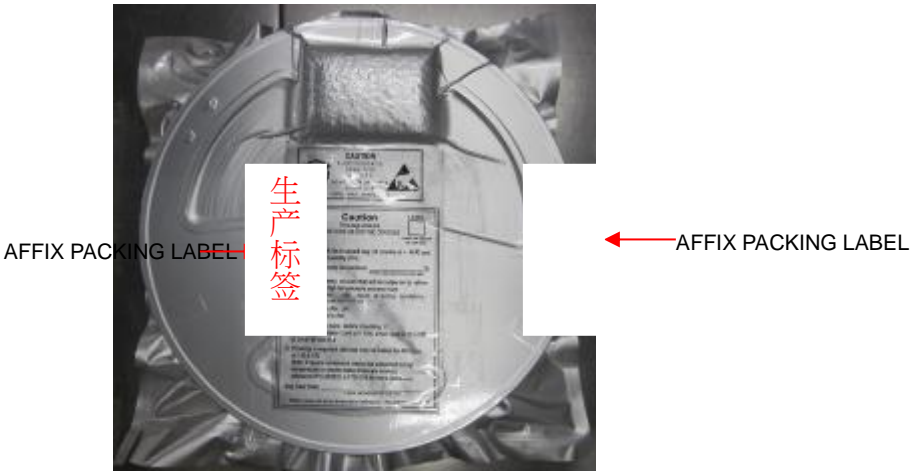

5.3



PINK BUBBLE WRAP

5.4



AFFIX PACKING LABEL

5.5

1 Carton= 5 Boxes



AFFIX PACKING LABEL

5.6



AFFIX PACKING LABEL