

AW-CM572-SUR

IEEE 802.11 a/b/g/n/ac WLAN 2T2R with Bluetooth 5.0 Combo LGA Module

Datasheet

Rev.B

DF

(For Standard)

1

Features

WLAN

- IEEE 802.11ac Wave-2 compliant.
- Dual-stream spatial multiplexing up to 867 Mbps data rate.
- Supports 20, 40, and 80 MHz channels with optional SGI (256 QAM modulation).
- Full IEEE 802.11a/b/g/n legacy compatibility with enhanced performance.
- TX and RX low-density parity check (LDPC) support for improved range and power efficiency.
- Supports IEEE 802.11ac/n beamforming.
- Supports RSDB.
- On-chip power amplifiers and low-noise amplifiers for both bands.
- Supports multipoint external coexistence interface to optimize bandwidth utilization with other co-located wireless technologies such as LTE and GPS.
- PCIe mode complies with PCI Express base specification
- Revision 3.0 for ×1 lane and power management running at Gen1 speed.
- Worldwide regulatory support: Global products supported with worldwide homologated design.
- Integrated Arm® Cortex® -R4 processor with tightly coupled memory for complete WLAN subsystem functionality, minimizing the need to

wakeup the applications processor for standard WLAN functions. This allows for further minimization of power consumption, while maintaining the ability to field upgrade with future features.

- With 2G internal Bandpass Filter.

Bluetooth

- Complies with Bluetooth Core Specification v5.0 with provisions for supporting future specifications.
- Supports all BT5.0 optional features including LE-2Mbps, LE-Long Range, LE-Advertising extensions.
- Bluetooth Class 1 or Class 2 transmitter operation.
- Supports extended synchronous connections (eSCO), for enhanced voice quality by allowing for retransmission of dropped packets.
- Adaptive frequency hopping (AFH) for reducing radio frequency interference.
- Interface support, host controller interface (HCI) using a high speed UART interface and PCM for audio data.

Bluetooth (continue)

- Supports multiple simultaneous Advanced Audio Distribution Profiles (A2DP) for stereo sound.

Table of Contents

Revision History.....	3
Table of Contents.....	4
1. Introduction	5
1.1 Product Overview	5
1.2 Block Diagram.....	5
1.3 Specifications Table	6
1.3.1 General	6
1.3.2 WLAN	6
1.3.3 Bluetooth.....	8
1.3.4 Operating Conditions.....	9
2. Pin Definition.....	10
2.1 Pin Map.....	10
2.2 Pin Table.....	11
3. Electrical Characteristics	14
3.1 Absolute Maximum Ratings	14
3.2 Recommended Operating Conditions	14
3.3 Digital IO Pin DC Characteristics	14
3.4 Power up Timing Sequence	15
3.4.1 SDIO Interface	18
3.4.2 UART Interface	20
3.5 Power Consumption*	23
3.5.1 WLAN	23
3.5.2 Bluetooth.....	23
4. Mechanical Information	24
4.1 Mechanical Drawing	24
5. Packaging Information	25

1. Introduction

1.1 Product Overview

AzureWave Technologies, Inc. introduces the advanced IEEE 802.11 ac/a/b/g/n 2x2 MIMO WLAN and Bluetooth M.2 combo module - AW-CM572-SUR. The Module is a complete dual-band (2.4 GHz and 5 GHz) Wi-Fi 2x2 MIMO MAC/PHY/Radio system-on-module. This 5G Wi-Fi single-chip device provides a high level of integration with a dual-stream IEEE 802.11ac MAC/baseband/radio and Bluetooth 5.0. In IEEE 802.11ac mode, the WLAN operation supports rates of MCS0–MCS9 (up to 256 QAM) in 20 MHz, 40 MHz, and 80 MHz channels for data rates up to 867 Mbps. In addition, all the rates specified in IEEE 802.11a/b/g/n are supported. Included on-chip are the 2.4 GHz and 5 GHz transmit power amplifiers and receive low-noise amplifiers. The WLAN operation supports two fully simultaneous SISO channels and real simultaneous dual-band (RSDB).

The WLAN section supports the following host interface options: an SDIO v3.0 interface that can operate in 4b or 1b mode.

For the Bluetooth section, Host interface is through a high-speed 4-wire UART interface and PCM interface for audio.

In addition, the AW-CM572-SUR implements highly sophisticated enhanced collaborative coexistence hardware mechanisms and algorithms that ensure that WLAN and Bluetooth collaboration is optimized for maximum performance. Coexistence support for external radios (such as LTE cellular and GPS) is provided via an external interface. As a result, enhanced overall quality for simultaneous voice, video, and data transmission on a Commercial/Consumer systems is achieved.

1.2 Block Diagram

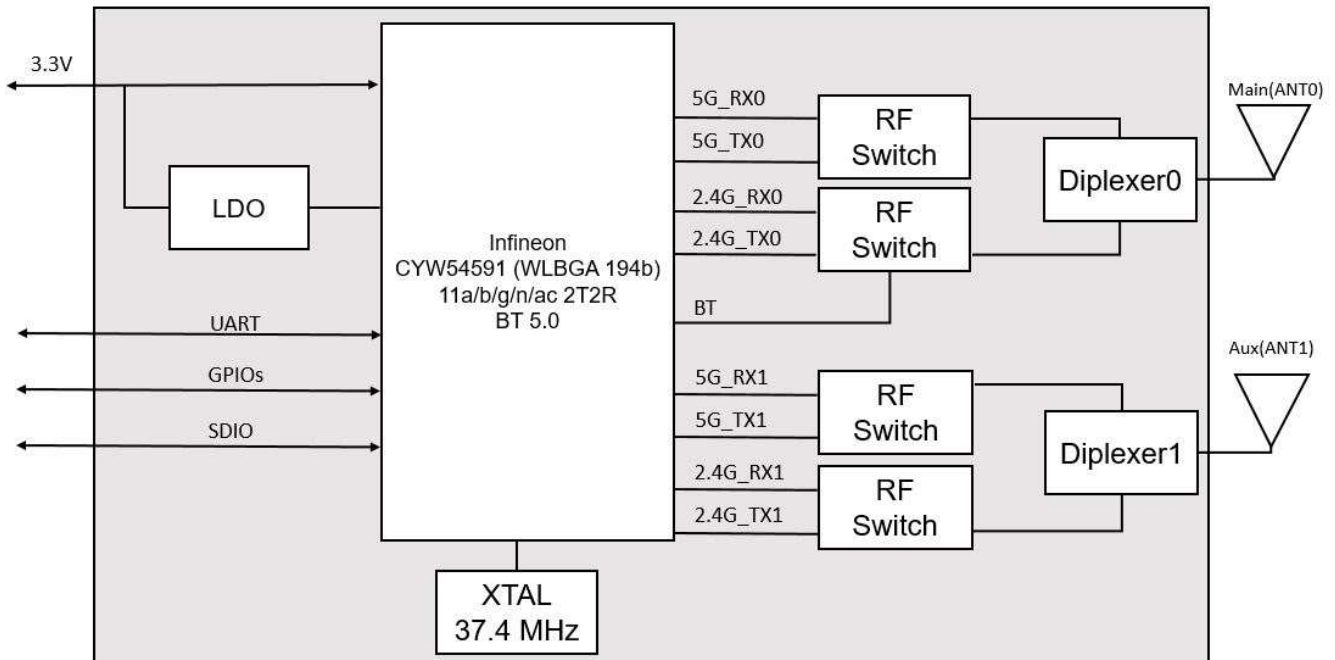

AW-CM572-SUR BLOCK DIAGRAM

1.3 Specifications Table

1.3.1 General

Features	Description
Product Description	IEEE 802.11 a/b/g/n/ac WLAN 2T2R with Bluetooth 5.0 Combo LGA Module
Major Chipset	Infineon CYW54591(wlbga 194b)
Host Interface	Wi-Fi +BT ● SDIO + UART
Dimension	15mm(L) x 13mm(W) x 1.95mm(H) (Tolerance remarked in mechanical drawing)
Form factor	LGA module, 50 pins
Antenna	External Antennas Design ANT0(Main) : WiFi/Bluetooth → TX/RX ANT1(AUX) : WiFi → TX/RX
Weight	TBD

1.3.2 WLAN

Features	Description
WLAN Standard	IEEE 802.11 a/b/g/n/ac 2T2R
WLAN VID/PID	N/A
WLAN SVID/SPID	N/A
Frequency Range	2.4 GHz : 2.412 ~ 2.484 GHz 5 GHz : 4.915 ~5.925GHz
Modulation	DSSS, OFDM, DBPSK, DQPSK, CCK, 16-QAM, 64-QAM, 256-QAM,
Number of Channels	2.4GHz ■ USA, NORTH AMERICA, Canada and Taiwan – 1 ~ 11 ■ China, Australia, Most European Countries – 1 ~ 13 5GHz ■ USA, EUROPE – 36, 40, 44, 48, 52, 56, 60, 64, 100, 104, 108, 112, 116, 120, 124, 128, 132, 136, 140, 149, 153, 157, 161, 165

Output Power (Board Level Limit)*	2.4G				
		Min	Typ	Max	Unit
	11b (11Mbps) @EVM<8%		TBD		dBm
	11g (54Mbps) @EVM ≤ -25 dB		TBD		dBm
	11n (HT20 MCS7) @EVM ≤ -28 dB		TBD		dBm
	11n (HT40 MCS7) @EVM ≤ -28 dB		TBD		dBm
	11n (VHT20 MCS7) @EVM ≤ -30 dB		TBD		dBm
	11n (VHT40 MCS9) @EVM ≤ -32 dB		TBD		dBm
	11ac (HE20 MCS7) @EVM ≤ -27 dB		TBD		dBm
	11ac (HE40 MCS9) @EVM ≤ -32 dB		TBD		dBm
	5G				
		Min	Typ	Max	Unit
	11a (54Mbps) @EVM<-25 dB		TBD		dBm
	11n (HT20 MCS7) @EVM ≤ -28 dB		TBD		dBm
	11n (HT40 MCS7) @EVM ≤ -28 dB		TBD		dBm
	11ac (VHT20 MCS7) @EVM ≤ -28 dB		TBD		dBm
	11ac (VHT40 MCS9) @EVM ≤ -30 dB		TBD		dBm
	11ac (VHT80 MCS9) @EVM ≤ -32 dB		TBD		dBm

Receiver Sensitivity	2.4G				
		Min	Typ	Max	Unit
	11b (11Mbps)		TBD		dBm
	11g (54Mbps)		TBD		dBm
	11n (HT20 MCS7)		TBD		dBm
	11n (HT40 MCS7)		TBD		dBm
	11ac(VHT20 MCS7)		TBD		dBm
	11ac(VHT40 MCS9)		TBD		dBm
	5G				
		Min	Typ	Max	Unit
	11a (54Mbps)		TBD		dBm
	11n (HT20 MCS7)		TBD		dBm
	11n (HT40 MCS7)		TBD		dBm
	11ac(VHT20 MCS7)		TBD		dBm
11ac(VHT40 MCS9)		TBD		dBm	
11ac(VHT80 MCS9)		TBD		dBm	
Data Rate	WLAN: 802.11b: 1, 2, 5.5, 11Mbps 802.11a/g: 6, 9, 12, 18, 24, 36, 48, 54Mbps 802.11n: up to 150Mbps-single 802.11n: up to 300Mbps-2x2 MIMO 802.11ac: up to 173.3Mbps (20MHz channel) 802.11ac: up to 400Mbps (40MHz channel) 802.11ac: up to 866.7Mbps (80MHz channel)				
Security	WPA, WAPI STA, and WPA2 (Personal) support for powerful encryption and authentication. AES and TKIP in hardware for faster data encryption and IEEE 802.11i compatibility. Reference WLAN subsystem provides Wi-Fi Protected Setup (WPS).				

* If you have any certification questions about output power please contact FAE directly.

1.3.3 Bluetooth

Features	Description
Bluetooth Standard	BT5.0+Enhanced Data Rate (EDR)
Bluetooth VID/PID	N/A
Frequency Range	2402~2483MHz

Modulation	GFSK (1Mbps), $\pi/4$ DQPSK (2Mbps) and 8DPSK (3Mbps)				
Output Power		Min	Typ	Max	Unit
	BDR		TBD		dBm
	EDR		TBD		dBm
	Low Energy (1MHz)		TBD		dBm
	Low Energy (2MHz)		TBD		dBm
Receiver Sensitivity		Min	Typ	Max	Unit
	BDR (BER<0.1%)		TBD		dBm
	EDR ($\pi/4$ DQPSK) (BER<0.07%)		TBD		dBm
	EDR (8PSK) (BER<0.07%)		TBD		dBm
	BLE(1M) (PER<-30.8%)		TBD		dBm
	BLE(S=2) (PER<-30.8%)		TBD		dBm
	BLE(S=8) (PER<-30.8%)		TBD		dBm
	BLE(2M) (PER<-30.8%)		TBD		dBm

1.3.4 Operating Conditions

Features	Description
Operating Conditions	
Voltage	Power supply for host:3.3V
Operating Temperature	-30°C~75°C
Operating Humidity	less than 85%R.H.
Storage Temperature	-30°C~ 85°C
Storage Humidity	less than 60%R.H.
ESD Protection	
Human Body Model	TBD
Changed Device Model	TBD

2. Pin Definition

2.1 Pin Map

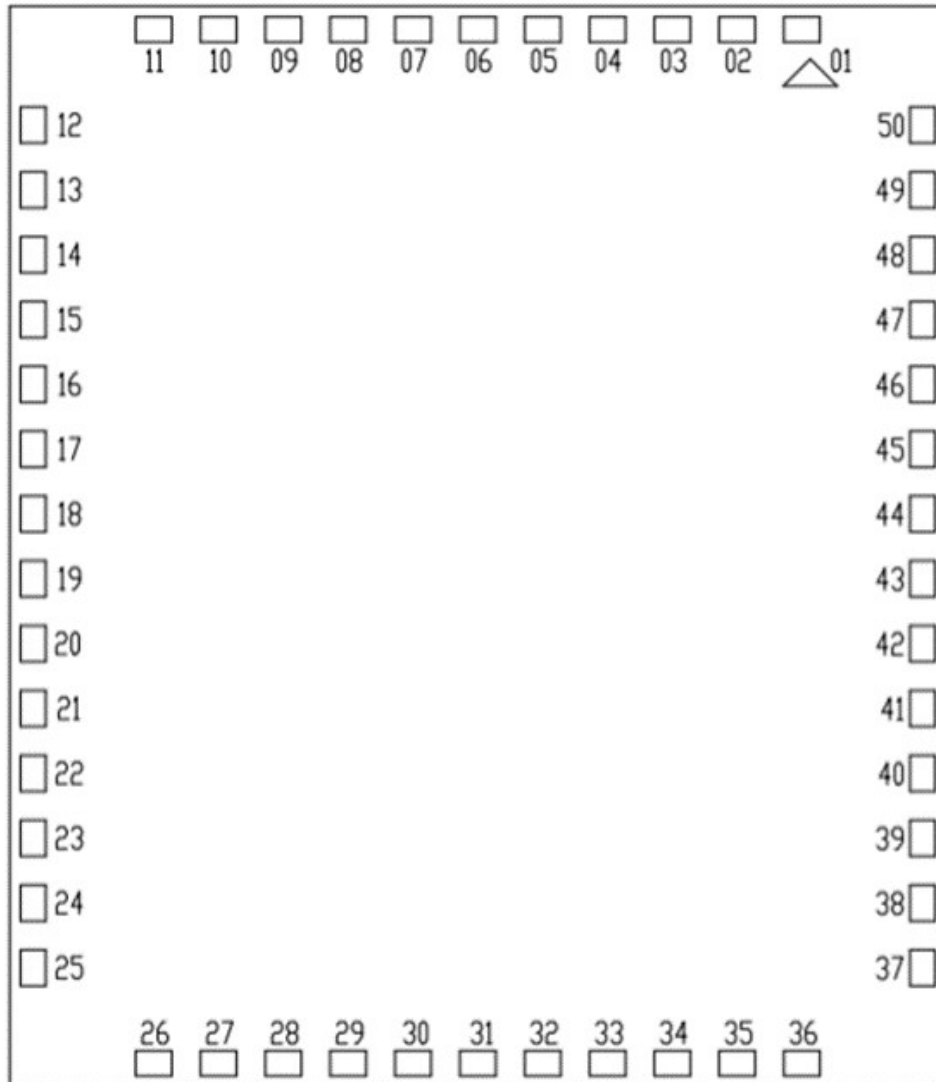

AW-CM572-SUR Pin Map (Bottom View)

2.2 Pin Table

Pin No	Definition	Basic Description	Voltage	Type
1	GND	System Ground Pin		
2	WL_ANT0	RF(BT&WIFI) I/O port0		I/O
3	GND	System Ground Pin		
4	GND	System Ground Pin		
5	GND	System Ground Pin		
6	GND	System Ground Pin		
7	GND	System Ground Pin		
8	GND	System Ground Pin		
9	WL_ANT1	RF(WIFI) I/O port1		I/O
10	GND	System Ground Pin		
11	GND	System Ground Pin		
12	NC	Floating (Don't connected to ground)		
13	NC	Floating (Don't connected to ground)		
14	NC	Floating (Don't connected to ground)		
15	WL_REG_ON	Low asserting reset for WiFi core	3V3	I
16	WL_HOST_WAKE	WLAN to wake-up HOST	1V8	O
17	SDIO_DATA_CMD	SDIO command line	1V8	I/O
18	SDIO_DATA_CLK	SDIO clock line	1V8	I/O
19	SDIO_DATA_3	SDIO data line 3	1V8	I/O
20	SDIO_DATA_2	SDIO data line 2	1V8	I/O
21	SDIO_DATA_0	SDIO data line 0	1V8	I/O
22	SDIO_DATA_1	SDIO data line 1	1V8	I/O

23	GND	System Ground Pin		
24	SDIO_VSEL	SDIO voltage select: 0: 3.3V 1:1.8V	3V3	I
25	VIN_LDO	Internal Buck voltage generation pin	1V35	P
26	VIN_LDO_OUT	Internal Buck voltage generation pin	1V35	P
27	PCM_SYNC	PCM sync signal	1V8	I/O
28	PCM_IN	PCM data input	1V8	I
29	PCM_OUT	PCM Data output	1V8	O
30	PCM_CLK	PCM clock	1V8	I/O
31	LPO	External Low Power Clock input (32.768KHz)		I
32	GND	System Ground Pin		
33	NC	Floating (Don't connected to ground)		
34	VDDIO	I/O Voltage supply input	1V8	P
35	NC	Floating (Don't connected to ground)		
36	VBAT	Main power voltage source input	3V3	P
37	NC	Floating (Don't connected to ground)		
38	BT_REG_ON	Low asserting reset for Bluetooth core	3V3	I
39	GND	System Ground Pin		
40	UART_TXD	Bluetooth UART interface	1V8	O
41	UART_RXD	Bluetooth UART interface	1V8	I
42	UART_RTS_N	Bluetooth UART interface	1V8	O
43	UART_CTS_N	Bluetooth UART interface	1V8	I
44	WL_UART_TX	WL_UART_TX	1V8	O
45	WL_UART_RX	WL_UART_RX	1V8	I

46	NC	Floating (Don't connected to ground)		
47	GND	System Ground Pin		
48	NC	Floating (Don't connected to ground)		
49	BT_WAKE	HOST wake-up Bluetooth device	1V8	I
50	BT_HOST_WAKE	Bluetooth device to wake-up HOST	1V8	O

3. Electrical Characteristics

3.1 Absolute Maximum Ratings

Symbol	Parameter	Minimum	Typical	Maximum	Unit
3.3V	DC supply voltage for VBAT and VDDIO.	-0.5	-	3.9	V

3.2 Recommended Operating Conditions

Symbol	Parameter	Minimum	Typical	Maximum	Unit
VBAT	DC supply voltage for VBAT and VDDIO.	3.0 ¹	3.3	3.6	V

3.3 Digital IO Pin DC Characteristics

Symbol	Parameter	Minimum	Typical	Maximum	Unit
Digital I/O pins, VDDIO=1.8V					
V _{IH}	Input high voltage	0.65 × VDDIO	-	-	V
V _{IL}	Input low voltage	-	-	0.35 × VDDIO	V
V _{OH}	Output high voltage	VDDIO – 0.45	-	-	V
V _{OL}	Output Low Voltage	-	-	0.45	V
Digital I/O pins, VDDIO=3.3V					
V _{IH}	Input high voltage	2.00	-	-	V
V _{IL}	Input low voltage	-	-	0.80	V
V _{OH}	Output high voltage	VDDIO – 0.4	-	-	V
V _{OL}	Output low Voltage	-	-	0.40	V

¹ AW-CM572-SUR-SUR is functional across this range of voltages. Optimal RF performance specified in the data sheet, however, is guaranteed only for 3.2V < VBAT < 3.6V.

3.4 Power up Timing Sequence

The AW-CM572-SUR has two signals that allow the host to control power consumption by enabling or disabling the Bluetooth, WLAN, and internal regulator blocks. These signals are described below. Additionally, diagrams are provided to indicate proper sequencing of the signals for various operational states. The timing values indicated are minimum required values; longer delays are also acceptable.

Description of Control Signals (Power-Up/Power-Down/Reset Control Signals)

Signal	Description
W_DISABLE1 (WL_REG_ON)	Used by the PMU to power up the WLAN section. It is also OR-gated with the W_DISABLE2(BT_REG_ON) input to control the internal AW-CM572-SUR regulators. When this pin is high, the regulators are enabled and the WLAN section is out of reset. When this pin is low the WLAN section is in reset. If both the W_DISABLE2(BT_REG_ON) and W_DISABLE1(WL_REG_ON) pins are low, the regulators are disabled.
W_DISABLE2 (BT_REG_ON)	Used by the PMU (OR-gated with W_DISABLE1) to power up the internal AW-CM572-SUR regulators. If both the W_DISABLE2(BT_REG_ON) and W_DISABLE1(WL_REG_ON) pins are low, the regulators are disabled. When this pin is low and W_DISABLE1(WL_REG_ON), the BT section is in reset.

Control Signal Timing Diagrams

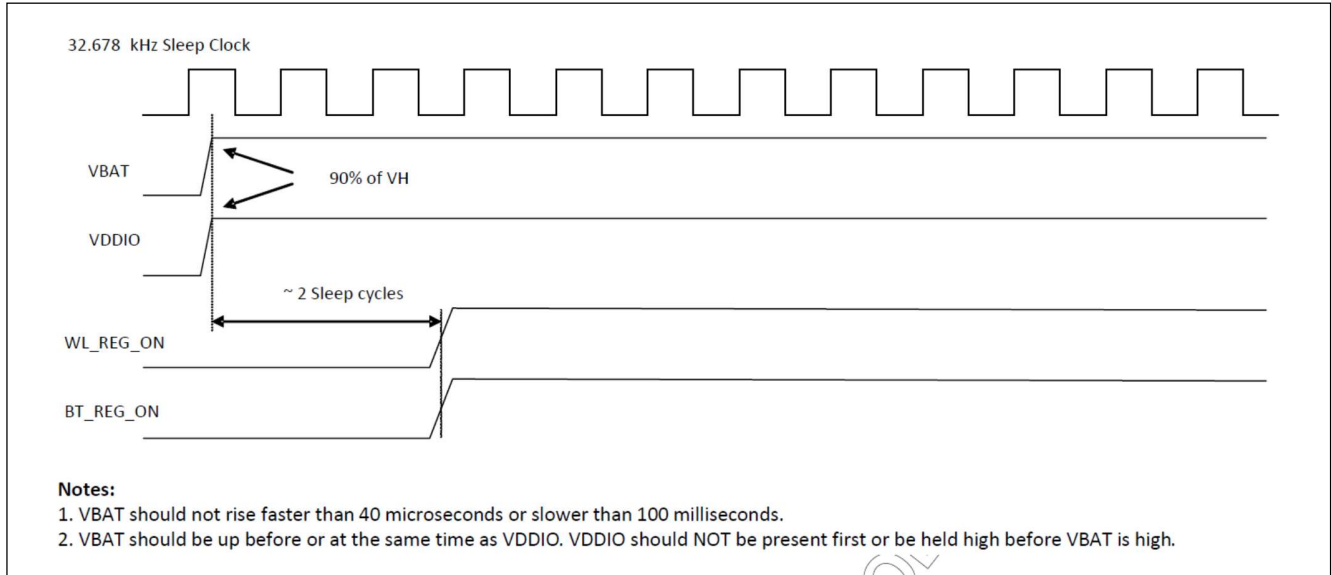
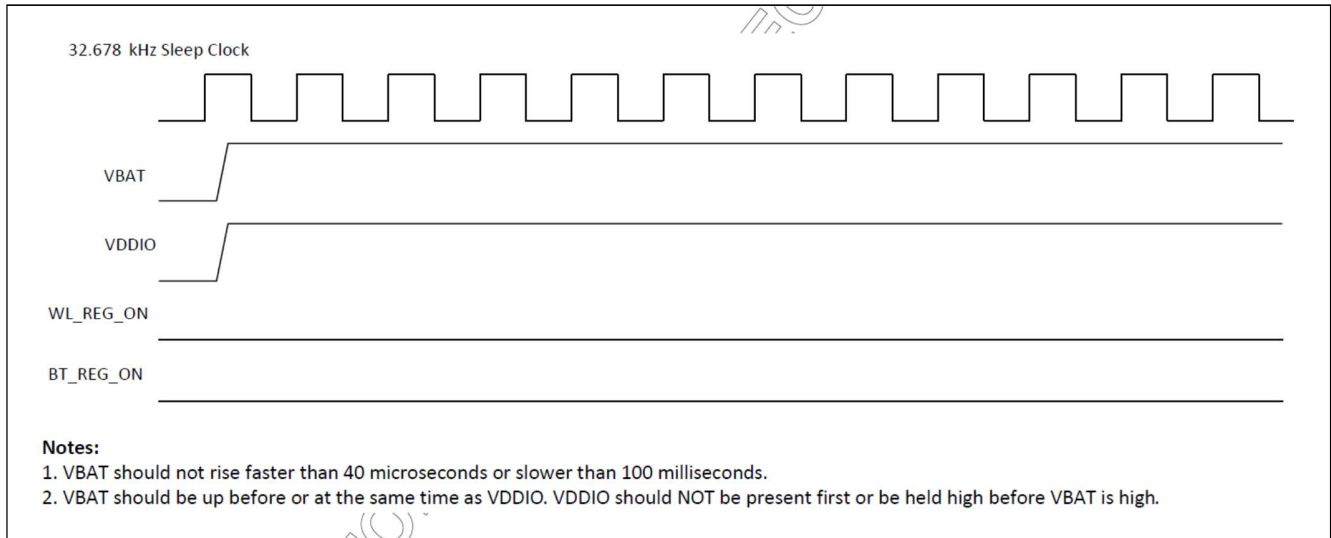
WLAN = ON, Bluetooth = ON

WLAN = OFF, Bluetooth = OFF

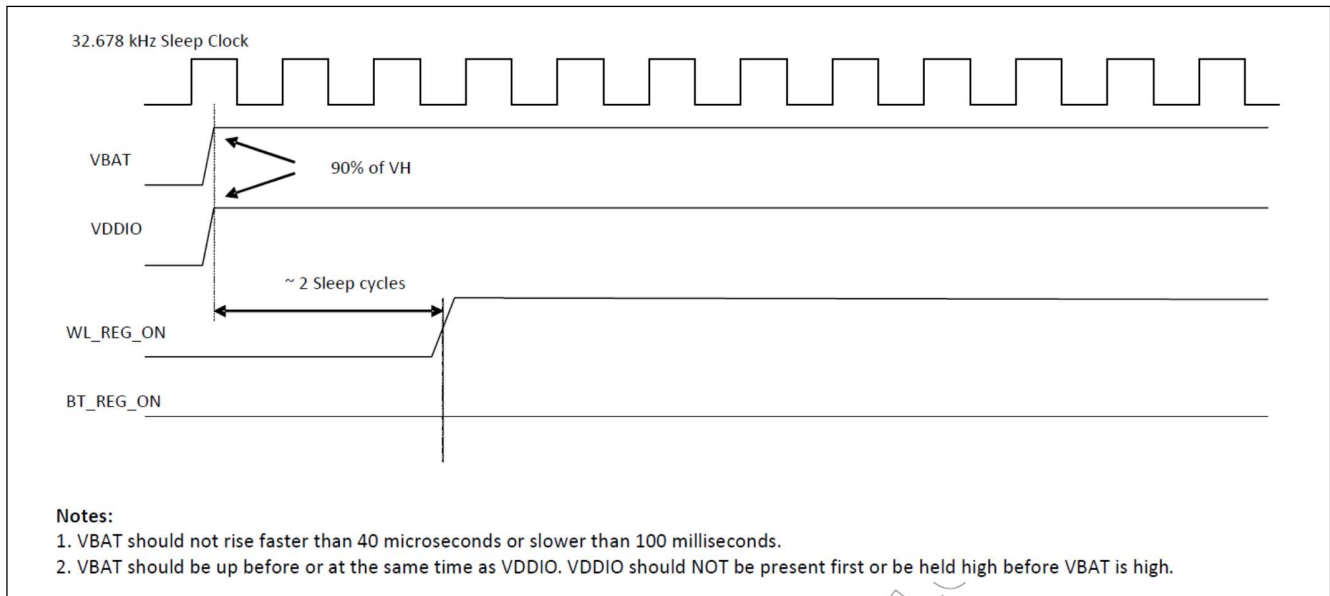
WLAN = ON, Bluetooth = OFF

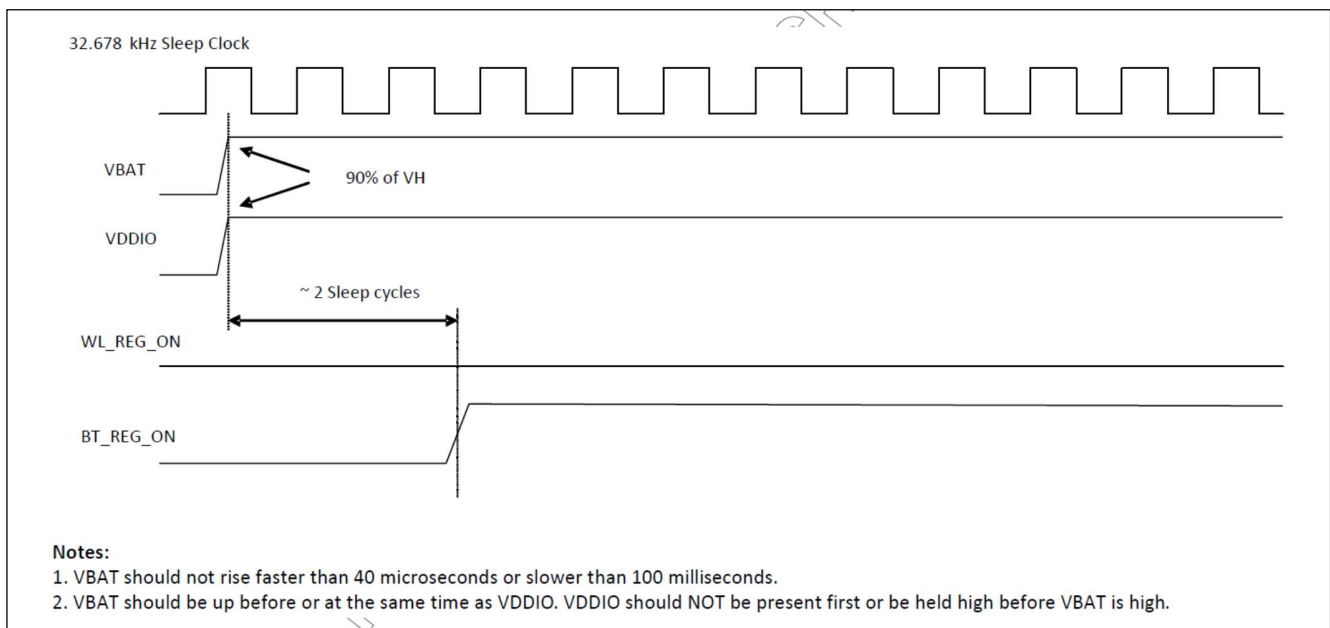

WLAN = OFF, Bluetooth = ON



3.4.1 SDIO Interface

SDIO Bus Timing (Default Mode)

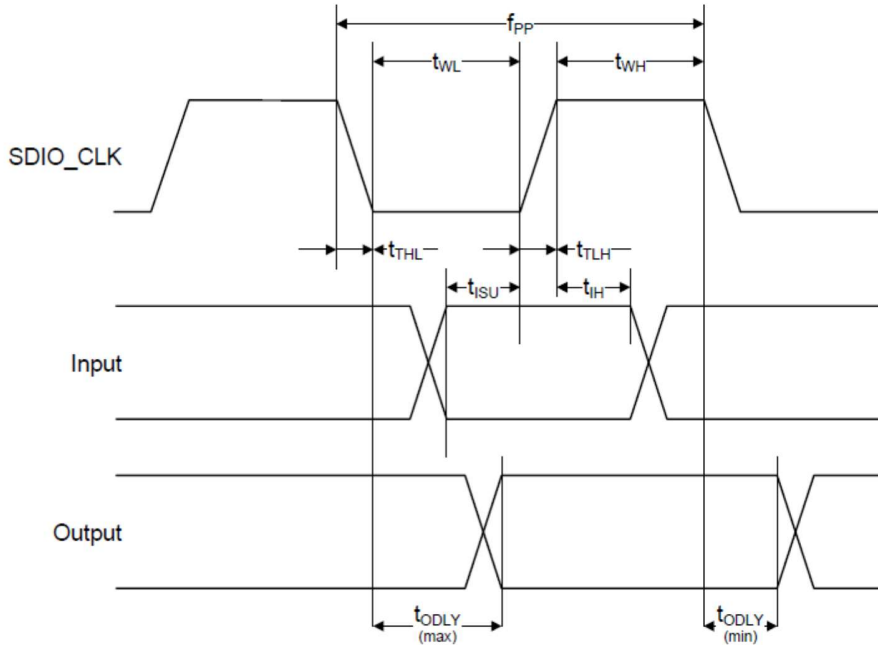

SDIO Bus Timing Parameters (Default Mode)

Parameter	Symbol	Minimum	Typical	Maximum	Unit
SDIO CLK (All values are referred to minimum VIH and maximum VIL)					
Frequency – Data Transfer mode	f_{PP}	0	–	25	MHz
Frequency – Identification mode	f_{OD}	0	–	400	kHz
Clock low time	t_{WL}	10	–	–	ns
Clock high time	t_{WH}	10	–	–	ns
Clock rise time	t_{TLH}	–	–	10	ns
Clock low time	t_{THL}	–	–	10	ns
Inputs: CMD, DAT (referenced to CLK)					
Input setup time	t_{ISU}	5	–	–	ns
Input hold time	t_{IH}	5	–	–	ns

Outputs: CMD, DAT (referenced to CLK)					
Output delay time – Data Transfer mode	t_{ODLY}	0	–	14	ns
Output delay time – Identification mode	t_{ODLY}	0	–	50	ns

SDIO Bus Timing (High-Speed Mode)

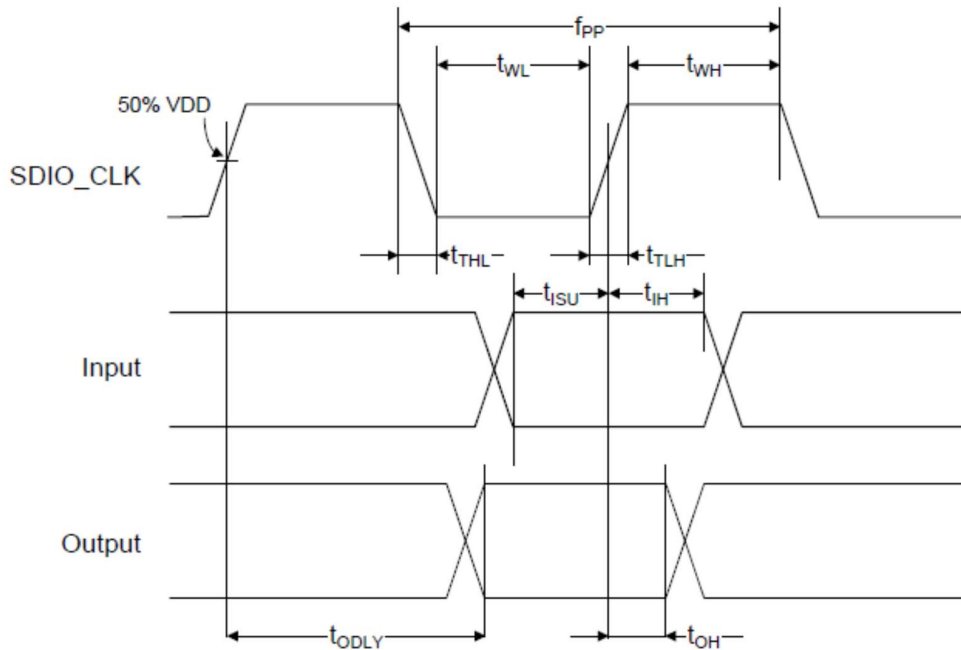

SDIO Bus Timing Parameters (High-Speed Mode)

Parameter	Symbol	Minimum	Typical	Maximum	Unit
SDIO CLK (all values are referred to minimum VIH and maximum VIL^b)					
Frequency – Data Transfer Mode	f_{PP}	0	–	50	MHz
Frequency – Identification Mode	f_{OD}	0	–	400	kHz
Clock low time	t_{WL}	7	–	–	ns
Clock high time	t_{WH}	7	–	–	ns
Clock rise time	t_{TLH}	–	–	3	ns
Clock low time	t_{THL}	–	–	3	ns

Inputs: CMD, DAT (referenced to CLK)					
Input setup Time	t_{ISU}	6	–	–	ns
Input hold Time	t_{IH}	2	–	–	ns
Outputs: CMD, DAT (referenced to CLK)					
Output delay time – Data Transfer Mode	t_{ODLY}	–	–	14	ns
Output hold time	t_{OH}	2.5	–	–	ns
Total system capacitance (each line)	CL	–	–	40	pF

3.4.2 UART Interface

The AW-CM572-SUR UART is a standard 4-wire interface (RX, TX, RTS, and CTS) with adjustable baud rates from 9600 bps to 4.0 Mbps. The interface features an automatic baud rate detection capability that returns a baud rate selection. Alternatively, the baud rate may be selected through a vendor-specific UART HCI command.

UART has a 1040-byte receive FIFO and a 1040-byte transmit FIFO to support EDR. Access to the FIFOs is conducted through the AHB interface through either DMA/CPU. The UART supports the Bluetooth 5.0 UART HCI specification: H4, and H5. The default baud rate is 115.2 Kbaud.

The UART supports the 3-wire H5 UART transport, as described in the Bluetooth specification (“3-wire UART Transport Layer”). Compared to H4, the H5 UART transport reduces the number of signal lines required by eliminating the CTS and RTS signals.

The CYW54591 UART can perform XON/XOFF flow control and includes hardware support for the Serial Line Input Protocol (SLIP). It can also perform wake-on activity. For example, activity on the RX or CTS inputs can wake the chip from a sleep state.

Normally, the UART baud rate is set by a configuration record downloaded after device reset, or by automatic baud rate detection, and the host does not need to adjust the baud rate. Support for changing the baud rate during normal HCI UART operation is included through a vendor-specific command that allows the host to adjust the contents of the baud rate registers. The AW-CM572-SUR UARTs operate correctly with the host UART as long as the combined baud rate error of the two devices is within $\pm 2\%$. UART Interface Signals

UART Interface Signals

PIN No.	Name	Description	Type
40	BT_UART_TXD	Bluetooth UART Serial Output. Serial data output for the HCI UART Interface	O
41	BT_UART_RXD	Bluetooth UART Series Input. Serial data input for the HCI UART Interface	I
42	BT_UART_RTS_N	Bluetooth UART Request-to-Send. Active-low request-to-send signal for the HCI UART interface	O
43	BT_UART_CTS_N	Bluetooth UART Clear-to-Send. Active-low clear-to-send signal for the HCI UART interface.	I

Example of Common Baud Rates

Desired Rate	Actual Rate	Error (%)
4000000	4000000	0.00
3692000	3692308	0.01
3000000	3000000	0.00
2000000	2000000	0.00
1500000	1500000	0.00
1444444	1454544	0.70
921600	923077	0.16
460800	461538	0.16
230400	230796	0.17
115200	115385	0.16
57600	57692	0.16
38400	38400	0.00
28800	28846	0.16
19200	19200	0.00
14400	14423	0.16
9600	9600	0.00

UART Timing

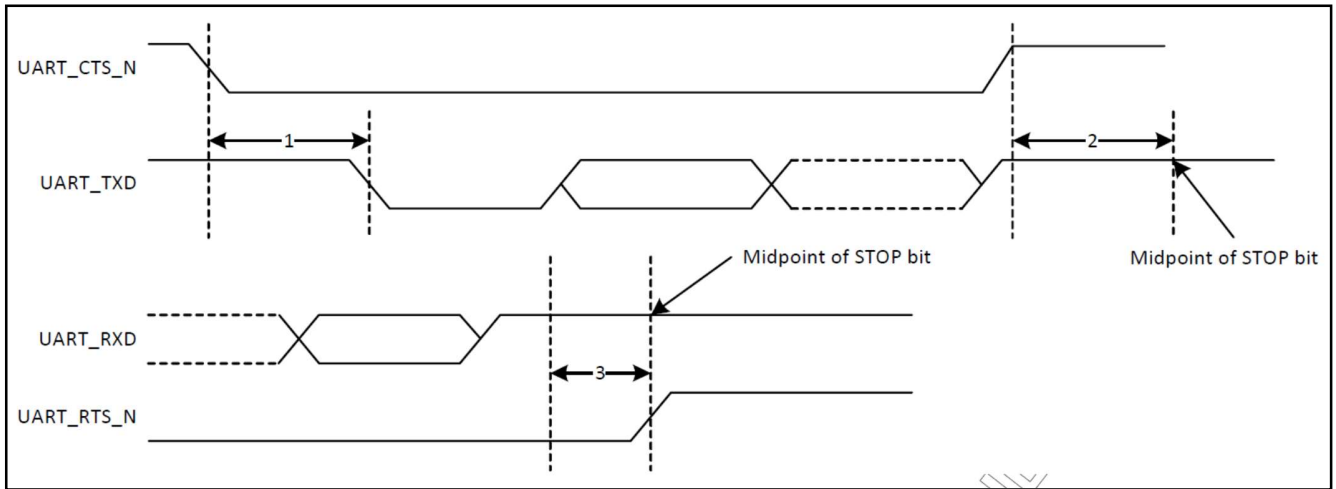

UART Timing Specifications

Ref No.	Characteristics	Minimum	Typical	Maximum	Unit
1	Delay time, UART_CTS_N low to UART_TXD valid	–	–	1.5	Bit periods
2	Setup time, UART_CTS_N high before midpoint of stop bit	–	–	0.5	Bit periods
3	Delay time, midpoint of stop bit to UART_RTS_N high	–	–	0.5	Bit periods

3.5 Power Consumption*

3.5.1 WLAN

Band (GHz)	Mode	BW (MHz)	Link Speed (Mbps)	Voltage=3.3V			
				Transmit		Receive	
				Max.	Avg.	Max.	Avg.
2.4	802.11b	20	11	TBD	TBD	TBD	TBD
	802.11g	20	54	TBD	TBD	TBD	TBD
	802.11n	20	144.4	TBD	TBD	TBD	TBD
		40	300	TBD	TBD	TBD	TBD
	802.11ax	20	286.5	TBD	TBD	TBD	TBD
		40	573.5	TBD	TBD	TBD	TBD
5	802.11a	20	54	TBD	TBD	TBD	TBD
	802.11n	20	144.4	TBD	TBD	TBD	TBD
		40	300	TBD	TBD	TBD	TBD
	802.11ac	20	173.3	TBD	TBD	TBD	TBD
		40	400	TBD	TBD	TBD	TBD
		80	866.7	TBD	TBD	TBD	TBD
	802.11ax	20	286.5	TBD	TBD	TBD	TBD
		40	573.5	TBD	TBD	TBD	TBD
80		1201	TBD	TBD	TBD	TBD	

* The power consumption is based on AzureWave test environment, these data for reference only.

3.5.2 Bluetooth

No.	Mode	Voltage=3.3 V	
		Max.	Avg.
1	Bluetooth RF Off	TBD	TBD
2	No Connection with any BT device	TBD	TBD
3	Connect BT Device	TBD	TBD
4	Transmit by BER 2.1	TBD	TBD
5	Receiver by BER 2.1	TBD	TBD

* The power consumption is based on AzureWave test environment, these data for reference only.

4. Mechanical Information

4.1 Mechanical Drawing

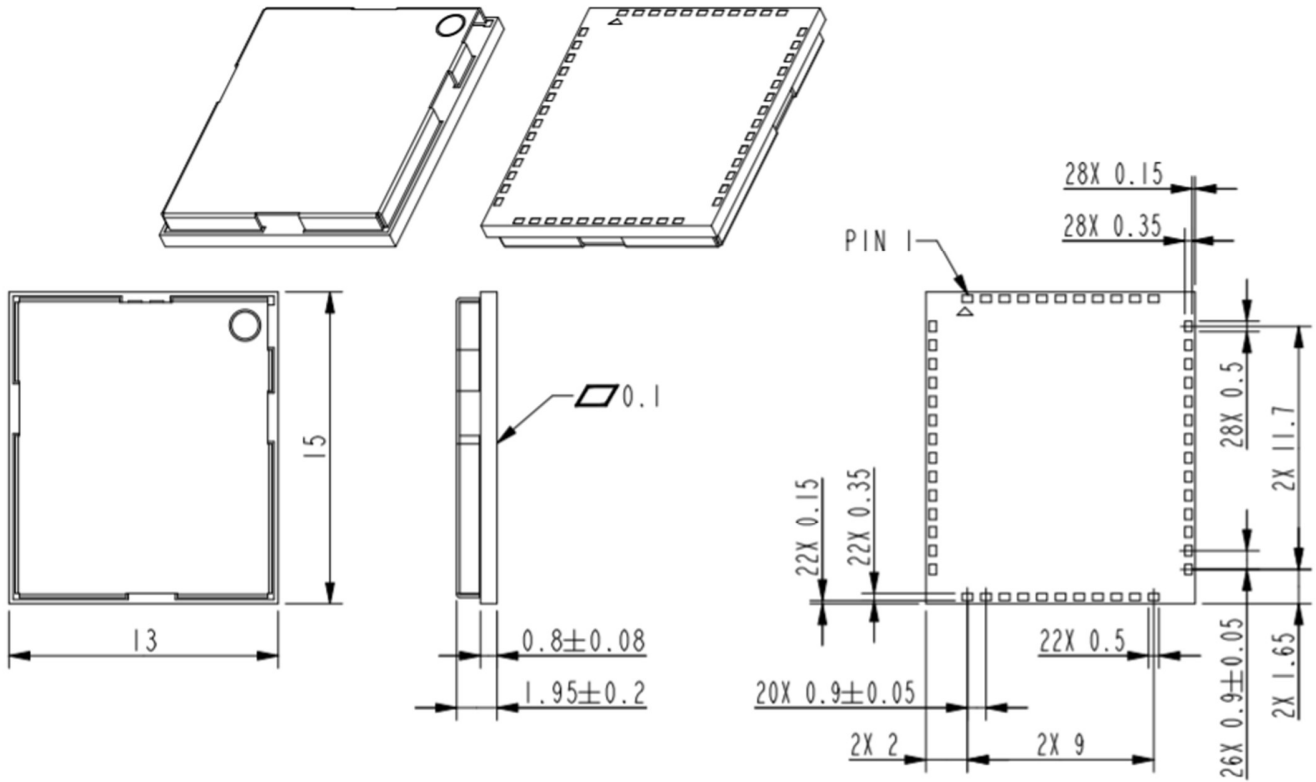



5. Packaging Information

5.1 Label level package

TBD