

正基科技股份有限公司

SPECIFICATION

PRODUCT NAME : AP6398S

REVISION : 1.6

DATE : May 20th, 2020

Customer APPROVED	
Company	
Representative Signature	

PREPARED	REVIEW			APPROVED	DCC ISSUE
	PM	QA	ET		



正基科技股份有限公司



AP6398S Data Sheet

Address:

3F, No.15-1 Zhonghua Road, Hsinchu Industrial Park, Hukou,
Hsinchu, Taiwan, 30352
<http://www.ampak.com.tw>



Revision

Revision	Date	Description	Revised By
0.1	2017/06/03	- Preliminary	Richard
0.2	2017/06/07	- Modify RF Spec	Richard
0.3	2017/06/07	- Modify BT 4.2 to BT 5.0 - Modify Vbat operation range	Richard
0.4	2017/08/24	- Modify Recommended Reflow Profile	Richard
0.5	2017/09/29	- Modify Supply voltage range	Richard
1.0	2018/06/15	-Update new version data sheet	Ali
1.1	2018/07/06	- Modify Product Features	Ali
1.2	2019/03/29	-Modify Block Diagram -Modify 2.4GHz Wi-Fi support channel list	Richard
1.3	20219/09/25	- Modify Label - Modify Bluetooth Specification	Jason
1.4	2019/11/15	- Modify footprint define - Add ESD Specificatin - Add External 37.4MHz X`tal characteristics	Jason
1.5	2020/03/19	-Update operating temperature -Update Bluetooth sensitivity specification	Jason
1.6	2020/05/20	-Update Module Dimensions	Richard

Contents

1. Introduction	2
1.1 Overview	2
1.2 Product Features	3
2. General Specification	4
2.1 General Specification	4
2.2 DC Characteristics	4
2.2.1 Absolute Maximum Ratings	4
2.2.2 Recommended Operating Rating	5
3. Wi-Fi RF Specification	6
3.1 2.4GHz RF Specification	6
3.2 5GHz RF Specification	8
4. Bluetooth Specification	12
4.1 Bluetooth Specification	12
5. Pin Definition	13
5.1 Pin Outline	13
5.2 Pin Assignment	13
6. Dimensions	15
6.1 Module Dimensions	15
6.2 Recommended footprint	16
7. External clock reference	17
8. Host Interface Timing Diagram	18
8.1 Power-up Sequence Timing Diagram	18
8.2 SDIO Interface Description	20
8.3 SDIO Default Mode Timing Diagram	21
8.4 SDIO High Speed Mode Timing Diagram	22
8.5 SDIO Bus Timing Specifications in SDR Modes	23
8.6 SDIO Bus Timing Specifications in DDR50 Mode	25
9. Recommended Reflow Profile	27
10. Package Information	28
10.1 Label	28
10.2 Dimension	29
10.3 MSL Level / Storage Condition	31



1. Introduction

1.1 Overview

The AMPAK Technology® AP6398S is a fully Wi-Fi and Bluetooth functionalities module with seamless roaming capabilities and advance security, also it could interact with different vendors' 802.11a/b/g/n/ac 2x2 Access Points with MIMO standard and can accomplish up to speed of 867Mbps with dual stream in 802.11n to connect the wireless LAN. Furthermore AP6398S included SDIO interface for Wi-Fi, UART/ PCM interface for Bluetooth.

In addition, this compact module is a total solution for a combination of Wi-Fi + BT technologies. The module is specifically developed for tablet, OTT box and portable devices.

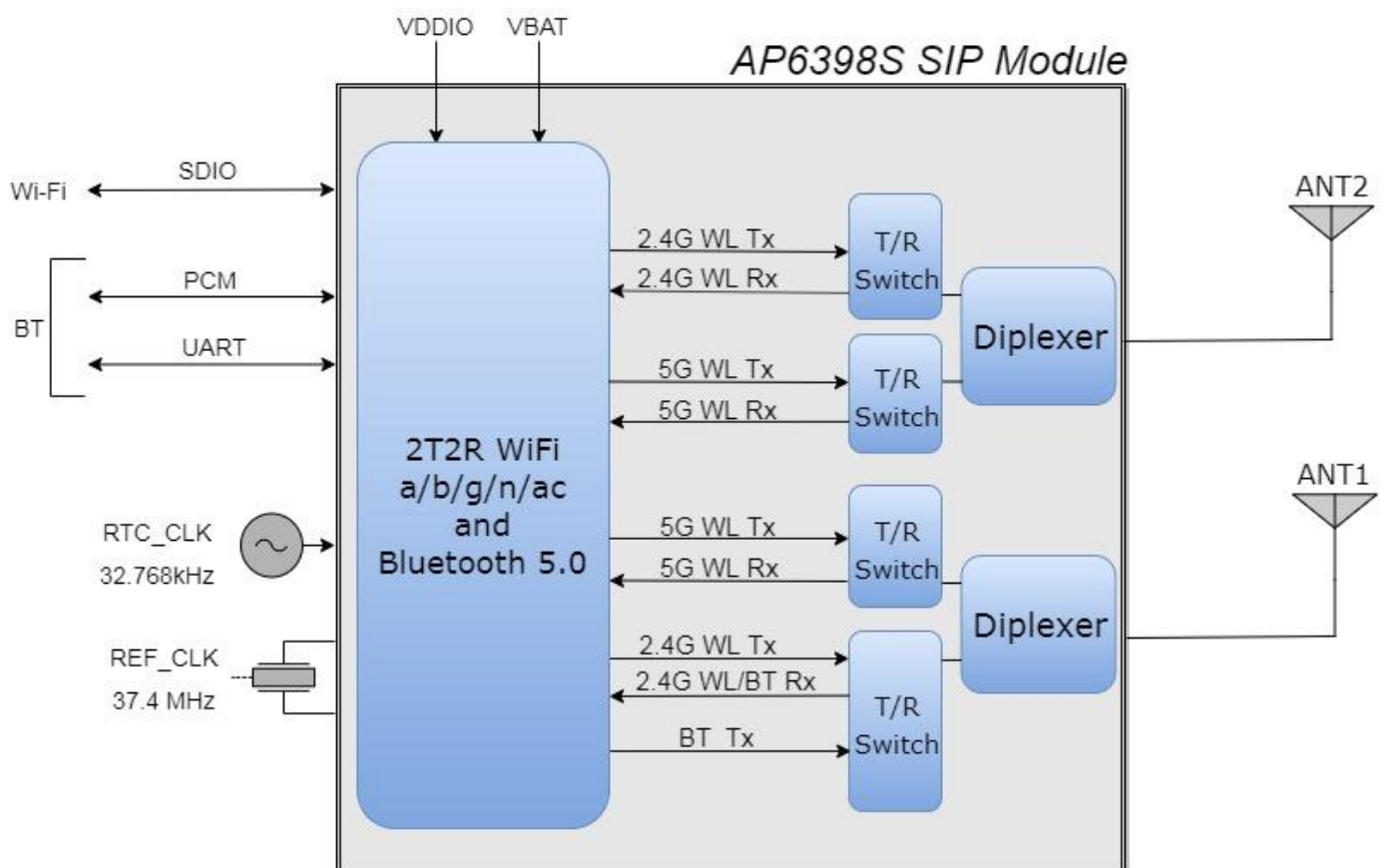

1.2 Product Features

- Lead Free design which is compliant with ROHS requirements.
 - TX and RX low-density parity check (LDPC) support for improved range and power efficiency.
 - Dual-stream spatial multiplexing up to 867 Mbps data rate.
 - 20, 40, 80 MHz channels with optional SGI (256 QAM modulation)
 - IEEE 802.11 ac/n beam forming.
 - Real simultaneous dual-band (RSDB)
 - Supports 2 antennas with one for WLAN & Bluetooth shared port and one WLAN port. Also, shared Bluetooth and WLAN receive signal path eliminates the need for an external power splitter while maintaining excellent sensitivity for both Bluetooth and WLAN.
 - Supports standard SDIO v3.0, compatible with SDIO v2.0 HOST interfaces.
 - BT host digital interface:
 - HCI UART (up to 4 Mbps)
 - PCM for audio data
 - Complies with Bluetooth Core Specification Version 5.0 with provisions for supporting future specifications. With Bluetooth Class 1 or Class2 transmitter operation.
 - Supports extended synchronous connections (eSCO), for enhanced voice quality by allowing for retransmission of dropped packets.
 - Adaptive frequency hopping (AFH) for reducing radio frequency interference.
- A simplified block diagram of the module is depicted in the figure above.



2. General Specification

2.1 General Specification

Model Name	AP6398S
Product Description	2T2R 802.11 ac/a/b/g/n Wi-Fi + BT 5.0 Module
Dimension	L x W : 15 x 13 (typical) mm 、 H : 1.85 (Maximum) mm
WiFi Interface	Support SDIO V3.0/2.0
BT Interface	UART / PCM
Operating temperature	1. -30°C to 75°C 2. -30°C to 85°C with proper throttle control and should be validated in final product.
Storage temperature	-40°C to 85°C
Humidity	Operating Humidity 10% to 95% Non-Condensing

Note: The optimal RF performance specified in the data sheet, however, is guaranteed only -10 °C to +55 °C and 3.2V < VBAT < 3.8V without derating performance.

2.2 DC Characteristics

2.2.1 Absolute Maximum Ratings

Symbol	Description	Min.	Max.	Unit
VBAT	Input supply Voltage	-0.5	4.5	V
VDDIO	Digital/Bluetooth/SDIO/ I/O Voltage	-0.5	3.8	V

Extreme caution must be exercised to prevent electrostatic discharge (ESD) damage.

Symbol	Condition	ESD Rating	Unit
ESD_HAND_HBM	Human body model contact discharge per JEDEC EID/JESD22-A114	1	kV
ESD_HAND_CDM	Charged device model contact discharge per JEDEC EIA/JESD22-C101	250*	V

* The WLAN RF input pins are specified to +200V/-175V.

2.2.2 Recommended Operating Rating

The module requires two power supplies: VBAT and VDDIO.

Voltage rails	Min.	Typ.	Max.	Unit
VBAT	3.0	3.3	3.6	V
VDDIO	1.7	1.8,3.3	3.6	V
For VDDIO=1.8V				
VIH/VIL	1.27 (VIH)		0.58 (VIL)	V
VOH/VOL output@2mA	1.4 (VOH)		0.45 (VOL)	V
For VDDIO=3.3V				
VIH/VIL	2.0625 (VIH)		0.8 (VIL)	V
VOH/VOL output@2mA	2.9 (VOH)		0.4 (VOL)	V

VBAT current consumption 1200mA(Peak), when VBAT = 3.3V

3. Wi-Fi RF Specification

3.1 2.4GHz RF Specification

Conditions : VBAT=3.3V ; VDDIO=3.3V ; Temp:25°C

Feature	Description
WLAN Standard	IEEE 802.11b/g/n & Wi-Fi compliant
Frequency Range	2.400 GHz ~ 2.4835 GHz (2.4GHz ISM Band)
Number of Channels	2.4GHz : Ch1 ~ Ch13
Modulation	802.11b : DQPSK 、 DBPSK 、 CCK 802.11 g/n : OFDM /64-QAM 、 16-QAM 、 QPSK 、 BPSK

Output Power , tolerance ± 1.5 dB

The transmit EVM quality & spectrum mask are compliant with IEEE 802.11 standard

802.11b	1Mbps	2Mbps	5.5Mbps	11Mbps	
	17.5	17.5	17.5	17.5	
802.11g	6 、 9Mbps	12 、 18Mbps	24Mbps	36Mbps	48Mbps
	17.5	17.5	17	17	16.5
	54Mbps				
	16.5				
802.11n 20MHz	MCS0~2	MCS3	MCS4	MCS5	MCS6
	17.5	16.5	16.5	16	16
	MCS7				
	15.5				

Note: The specifications of RF output power are subject to change to fulfill the safety regulation and requirements in end-user product.

Sensitivity, tolerance ± 2 dB

CCK modulation PER $\leq 8\%$ 、 OFDM modulation PER $\leq 10\%$

802.11b	Data Rate	Spec.(dBm)		
	1Mbps	-96		
	2Mbps	-93		
	5.5Mbps	-91		
	11Mbps	-88		
802.11g SISO	Data Rate	Spec.(dBm)	Data Rate	Spec.(dBm)
	6Mbps	-92	24Mbps	-84
	9Mbps	-91	36Mbps	-81
	12Mbps	-90	48Mbps	-78
	18Mbps	-87	54Mbps	-76

802.11g MIMO	Data Rate	Spec.(dBm)	Data Rate	Spec.(dBm)
	6Mbps	-95	24Mbps	-87
	9Mbps	-94	36Mbps	-84
	12Mbps	-93	48Mbps	-81
	18Mbps	-90	54Mbps	-78
802.11n_20MHz SISO	Data Rate	Spec.(dBm)	Data Rate	Spec.(dBm)
	MCS0	-91	MCS4	-80
	MCS1	-89	MCS4	-78
	MCS2	-87	MCS6	-76
	MCS3	-78	MCS7	-74
802.11n_20MHz MIMO	Data Rate	Spec.(dBm)	Data Rate	Spec.(dBm)
	MCS0	-93	MCS5	-80
	MCS1	-92	MCS6	-78
	MCS2	-90	MCS7	-76
	MCS3	-87	MCS8	-92
	MCS4	-83	MCS15	-73
Maximum Input Level	802.11b : -10 dBm			
	802.11g/n : -20 dBm			

3.2 5GHz RF Specification

Conditions : VBAT=3.3V ; VDDIO=3.3V ; Temp:25°C

Feature	Description				
WLAN Standard	IEEE 802.11a/n/ac & Wi-Fi compliant				
Frequency Range	5.15~5.35GHz 、 5.47~5.725GHz 、 5.725~5.85GHz (5GHz UNII Band)				
Number of Channels	5.15~5.35GHz : Ch36 ~ Ch64 5.47~5.725GHz : Ch100 ~ Ch140 5.725~5.85GHz : Ch149 ~ Ch165				
Modulation	802.11a : OFDM /64-QAM 、 16-QAM 、 QPSK 、 BPSK 802.11n : OFDM /64-QAM 、 16-QAM 、 QPSK 、 BPSK 802.11ac : OFDM /256-QAM 、 OFDM /64-QAM 、 16-QAM 、 QPSK 、 BPSK				
Output Power , tolerance ± 1.5 dB					
The transmit EVM quality & spectrum mask are compliant with IEEE 802.11 standard					
802.11a	Frequency (MHz)	6~9Mbps	12~18Mbps	24Mbps	36Mbps
	5150~5350	16.5	16.5	16	16
	5470~5720	16.5	16.5	16	16
	5725~5845	16.5	16.5	16	16
	Frequency (MHz)	48Mbps	54Mbps		
	5150~5350	15.5	15.5		
	5470~5720	15.5	15.5		
	5725~5845	15.5	15.5		
802.11n 20MHz	Frequency (MHz)	MCS0~2	MCS3	MCS4	MCS5
	5150~5350	16	16	15.5	15.5
	5470~5720	16	16	15.5	15.5
	5725~5845	16	16	15.5	15.5
	Frequency (MHz)	MCS6	MCS7		
	5150~5350	14.5	14.5		
	5470~5720	14.5	14.5		
	5725~5845	14.5	14.5		
802.11n 40MHz	Frequency (MHz)	MCS0~2	MCS3	MCS4	MCS5
	5150~5350	16	16	15.5	15.5
	5470~5720	16	16	15.5	15.5
	5725~5845	16	16	15.5	15.5
	Frequency (MHz)	MCS6	MCS7		
	5150~5350	14.5	14.5		
	5470~5720	14.5	14.5		
	5725~5845	14.5	14.5		

802.11ac 20MHz	Frequency (MHz)	MCS0~2	MCS3	MCS4	MCS5
	5150~5350	16	16	15.5	15.5
	5470~5720	16	16	15.5	15.5
	5725~5845	16	16	15.5	15.5
	Frequency (MHz)	MCS6	MCS7	MCS8	
	5150~5350	14.5	14.5	12	
	5470~5720	14.5	14.5	12	
	5725~5845	14.5	14.5	12	
802.11ac 40MHz	Frequency (MHz)	MCS0~2	MCS3	MCS4	MCS5
	5150~5350	16	16	15.5	15.5
	5470~5720	16	16	15.5	15.5
	5725~5845	16	16	15.5	15.5
	Frequency (MHz)	MCS6	MCS7	MCS8	MCS9
	5150~5350	14.5	14.5	12	10
	5470~5720	14.5	14.5	12	10
	5725~5845	14.5	14.5	12	10
802.11ac 80MHz	Frequency (MHz)	MCS0~2	MCS3	MCS4	MCS5
	5150~5350	15	15	14	14
	5470~5720	15	15	14	14
	5725~5845	15	15	14	14
	Frequency (MHz)	MCS6	MCS7	MCS8	MCS9
	5150~5350	13	13	12	10
	5470~5720	13	13	12	10
	5725~5845	13	13	12	10

Note: The specifications of RF output power are subject to change to fulfill the safety regulation and requirements in end-user product.

Sensitivity, tolerance ± 1.5 dB

CCK modulation PER $\leq 8\%$ 、OFDM modulation PER $\leq 10\%$

802.11a SISO	Data Rate	Spec.(dBm)	Data Rate	Spec.(dBm)
	6Mbps	-91	24Mbps	-83
	9Mbps	-90	36Mbps	-80
	12Mbps	-88	48Mbps	-76
	18Mbps	-86	54Mbps	-74
802.11a MIMO	Data Rate	Spec.(dBm)	Data Rate	Spec.(dBm)
	6Mbps	-92	24Mbps	-86
	9Mbps	-91	36Mbps	-83
	12Mbps	-90	48Mbps	-78
	18Mbps	-89	54Mbps	-77

802.11n_20MHz SISO	Data Rate	Spec.(dBm)	Data Rate	Spec.(dBm)
	MCS0	-90	MCS4	-79
	MCS1	-88	MCS5	-76
	MCS2	-86	MCS6	-73
	MCS3	-83	MCS7	-72
802.11n_20MHz MIMO	Data Rate	Spec.(dBm)	Data Rate	Spec.(dBm)
	MCS0	-92	MCS5	-78
	MCS1	-91	MCS6	-76
	MCS2	-89	MCS7	-75
	MCS3	-86	MCS8	-89
	MCS4	-82	MCS15	-70
802.11n_40MHz SISO	Data Rate	Spec.(dBm)	Data Rate	Spec.(dBm)
	MCS0	-88	MCS4	-77
	MCS1	-86	MCS5	-72
	MCS2	-83	MCS6	-70
	MCS3	-80	MCS7	-69
802.11n_40MHz MIMO	Data Rate	Spec.(dBm)	Data Rate	Spec.(dBm)
	MCS0	-88	MCS5	-75
	MCS1	-88	MCS6	-73
	MCS2	-86	MCS7	-72
	MCS3	-83	MCS8	-86
	MCS4	-79	MCS15	-67
802.11ac_20MHz SISO	Data Rate	Spec.(dBm)	Data Rate	Spec.(dBm)
	MCS0	-90	MCS5	-75
	MCS1	-88	MCS6	-73
	MCS2	-86	MCS7	-70
	MCS3	-83	MCS8	-67
	MCS4	-79		
802.11ac_20MHz MIMO	Data Rate	Spec.(dBm)	Data Rate	Spec.(dBm)
	MCS0,NSS=1	-92	MCS6,NSS=1	-76
	MCS1,NSS=1	-91	MCS7,NSS=1	-75
	MCS2,NSS=1	-88	MCS8,NSS=1	-72
	MCS3,NSS=1	-85	MCS0,NSS=2	-88
	MCS4,NSS=1	-82	MCS8,NSS=2	-65
	MCS5,NSS=1	-77		

802.11ac_40MHz SISO	Data Rate	Spec.(dBm)	Data Rate	Spec.(dBm)
	MCS0	-88	MCS5	-72
	MCS1	-86	MCS6	-70
	MCS2	-83	MCS7	-69
	MCS3	-80	MCS8	-65
	MCS4	-76	MCS9	-63
802.11ac_40MHz MIMO	Data Rate	Spec.(dBm)	Data Rate	Spec.(dBm)
	MCS0,NSS=1	-90	MCS6,NSS=1	-73
	MCS1,NSS=1	-88	MCS7,NSS=1	-72
	MCS2,NSS=1	-86	MCS8,NSS=1	-68
	MCS3,NSS=1	-82	MCS9,NSS=1	-66
	MCS4,NSS=1	-79	MCS0,NSS=2	-86
	MCS5,NSS=1	-77	MCS9,NSS=2	-60
802.11ac_80MHz SISO	Data Rate	Spec.(dBm)	Data Rate	Spec.(dBm)
	MCS0	-85	MCS5	-68
	MCS1	-82	MCS6	-67
	MCS2	-79	MCS7	-65
	MCS3	-76	MCS8	-62
	MCS4	-73	MCS9	-60
802.11ac_80MHz MIMO	Data Rate	Spec.(dBm)	Data Rate	Spec.(dBm)
	MCS0,NSS=1	-87	MCS6,NSS=1	-70
	MCS1,NSS=1	-85	MCS7,NSS=1	-68
	MCS2,NSS=1	-82	MCS8,NSS=1	-66
	MCS3,NSS=1	-79	MCS9,NSS=1	-63
	MCS4,NSS=1	-76	MCS0,NSS=2	-83
	MCS5,NSS=1	-71	MCS9,NSS=2	-58
Maximum Input Level	802.11a/n/ac : -30 dBm			

4. Bluetooth Specification

4.1 Bluetooth Specification

Conditions : VBAT=3.3V ; VDDIO=3.3V ; Temp:25°C

Feature	Description	
General Specification		
Bluetooth Standard	GFSK 、 DQPSK 、 8DPSK 、 LE(1Mbps) 、 2LE(2Mbps)	
Host Interface	UART	
Frequency Band	2402 MHz ~ 2480 MHz	
Number of Channels	79 channels for classic 、 40 channels for BLE	
Modulation	FHSS, GFSK, DPSK, DQPSK	
RF Specification		
	CL1 (dBm)	CL2 (dBm)
BDR Output Power	6	2
EDR Output Power	4	2
LE Output Power	5	2
	Typical.	
Sensitivity @ BER=0.1% for GFSK (1Mbps)	-90 dBm	
Sensitivity @ BER=0.01% for $\pi/4$ -DQPSK (2Mbps)	-92 dBm	
Sensitivity @ BER=0.01% for 8DPSK (3Mbps)	-87 dBm	
Sensitivity @ BER=0.01% for LE (1Mbps)	-92 dBm	
Sensitivity @ BER=0.01% for LE (2Mbps)	-92 dBm	
Maximum Input Level	GFSK (1Mbps):-20dBm	
	$\pi/4$ -DQPSK (2Mbps) :-20dBm	
	8DPSK (3Mbps) :-20dBm	

Note* : The Bluetooth BDR output power is able to be configured by firmware (hcd file).



5. Pin Definition

5.1 Pin Outline

<TOP VIEW>

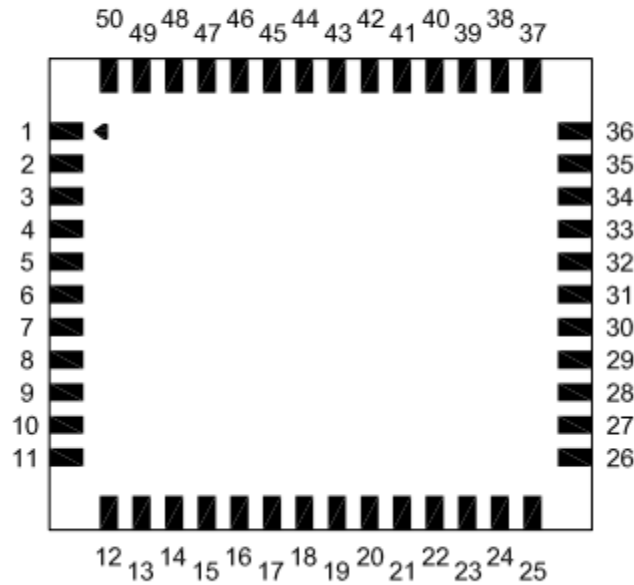

5.2 Pin Assignment

NO	Name	Type	Description
1	GND	—	Ground connections
2	WL_ANT0	I/O	RF(BT&WIFI) I/O port0
3	GND	—	Ground connections
4	GND	—	Ground connections
5	GND	—	Ground connections
6	GND	—	Ground connections
7	GND	—	Ground connections
8	GND	—	Ground connections
9	WL_ANT1	I/O	RF(WIFI) I/O port1
10	GND	—	Ground connections
11	GND	—	Ground connections
12	NC	—	Floating (Don't connected to ground)
13	XTAL_OUT	O	External Crystal out
14	XTAL_IN	I	External Crystal in/ Single clock source in
15	WL_REG_ON	I	Low asserting reset for WiFi core

16	WL_HOST_WAKE	O	WLAN to wake-up HOST
17	SDIO_DATA_CMD	I/O	SDIO command line
18	SDIO_DATA_CLK	I/O	SDIO clock line
19	SDIO_DATA_3	I/O	SDIO data line 3
20	SDIO_DATA_2	I/O	SDIO data line 2
21	SDIO_DATA_0	I/O	SDIO data line 0
22	SDIO_DATA_1	I/O	SDIO data line 1
23	GND	—	Ground connections
24	SDIO_VSEL	I	SDIO voltage select: 0: 3.3V 1:1.8V
25	VIN_LDO	P	Internal Buck voltage generation pin
26	VIN_LDO_OUT	P	Internal Buck voltage generation pin
27	PCM_SYNC	I/O	PCM sync signal
28	PCM_IN	I	PCM data input
29	PCM_OUT	O	PCM Data output
30	PCM_CLK	I/O	PCM clock
31	LPO	I	External Low Power Clock input (32.768KHz)
32	GND	—	Ground connections
33	NC	—	Floating (Don't connected to ground)
34	VDDIO	P	I/O Voltage supply input
35	NC	—	Floating (Don't connected to ground)
36	VBAT	P	Main power voltage source input
37	NC	—	Floating (Don't connected to ground)
38	BT_REG_ON	I	Low asserting reset for Bluetooth core
39	GND	—	Ground connections
40	UART_TXD	O	Bluetooth UART interface
41	UART_RXD	I	Bluetooth UART interface
42	UART_RTS_N	O	Bluetooth UART interface
43	UART_CTS_N	I	Bluetooth UART interface
44	WL_UART_TX	O	WL_UART_TX
45	WL_UART_RX	I	WL_UART_RX
46	NC	—	Floating (Don't connected to ground)
47	GND	—	Ground connections
48	NC	—	Floating (Don't connected to ground)
49	BT_WAKE	I	HOST wake-up Bluetooth device
50	BT_HOST_WAKE	O	Bluetooth device to wake-up HOST

6. Dimensions

6.1 Module Dimensions

<TOP VIEW>

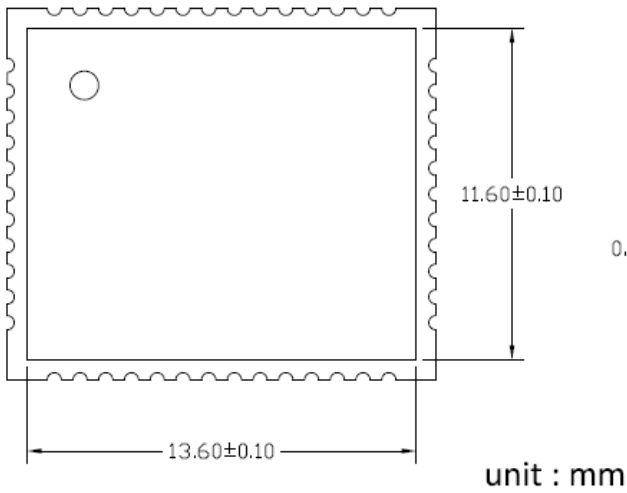

<BOTTOM VIEW>

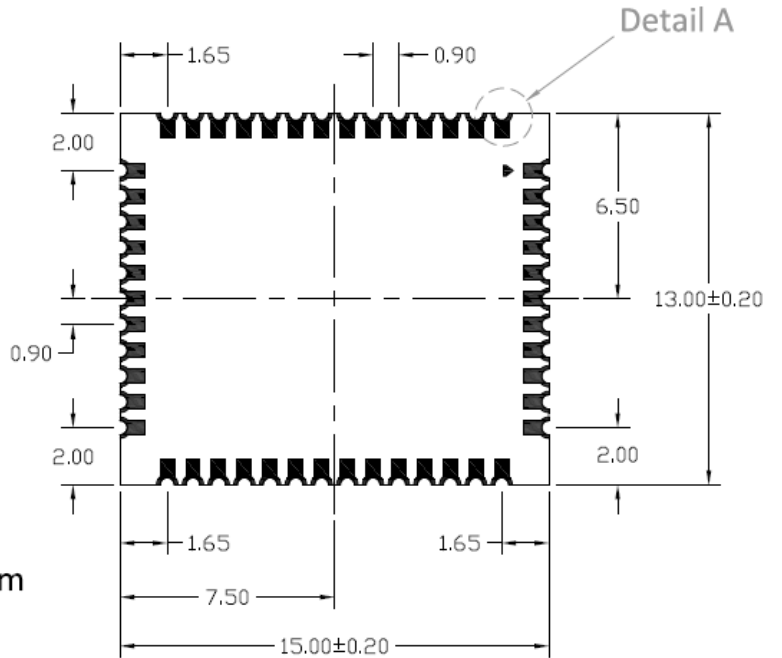

<SIDE VIEW>

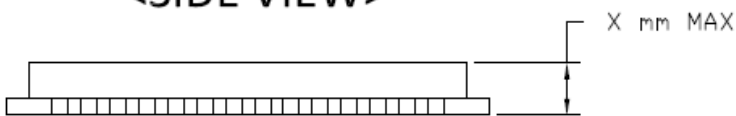

Note, X = 1.85mm

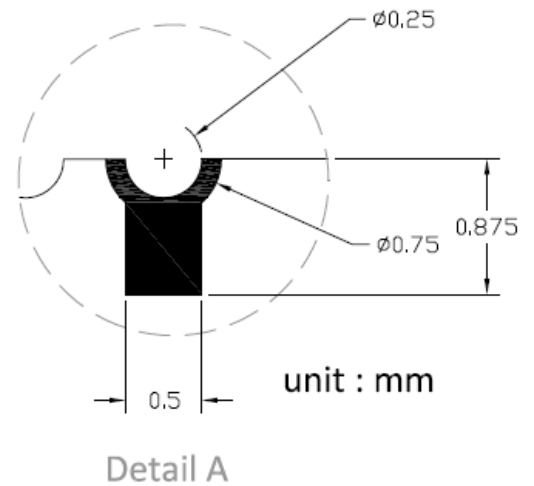

6.2 Recommended footprint

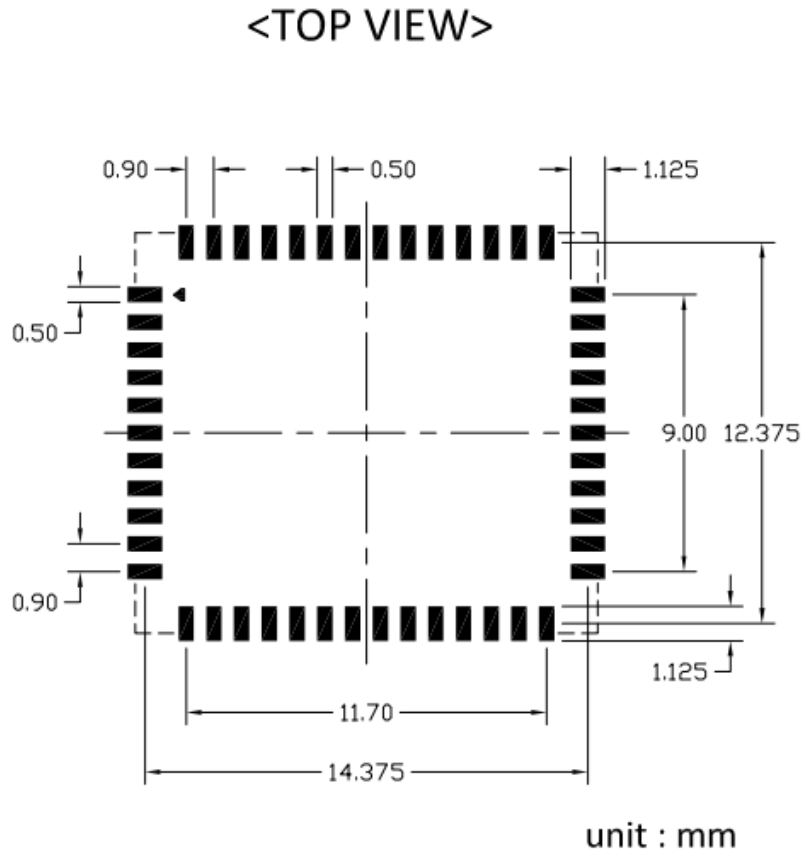

- Solder paste layer design is generally the same as recommended footprint.
(錫膏層設計通常建議和焊墊尺寸相同)
- If soldering quality with good wetting on upright side is essential for PQC, how to optimize the aperture design in the stencil to adjust the amount of solder paste would be crucial.
In addition, a kind of stencil design with stepped thickness in partial area would be considered if the thickness of stencil is about 0.1mm or thinner. Please optimize the stencil design by manufacture engineer or contact AMPAK FAE for assistance.
(如果模組吃錫品質考量側面爬錫，如何優化鋼網開孔設計以調整適當的錫膏量是非常重要的。尤其鋼網的厚度大約是 0.1mm 或更薄時，可考慮局部加厚鋼網的設計。請諮詢製程工程師以優化鋼網的設計，或是聯絡正基科技技術支持團隊)。

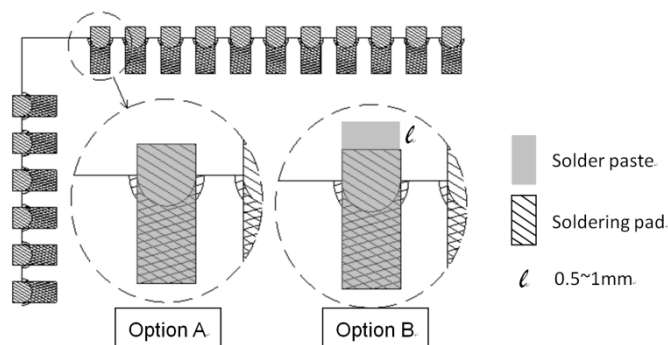

7. External clock reference

External LPO signal characteristics

Parameter	Specification	Units
Nominal input frequency	32.768	kHz
Frequency accuracy	+/-30	ppm
Duty cycle	30 - 70	%
Input signal amplitude	1600 to 3300	mV, p-p
Signal type	Square-wave or sine-wave	-
Input impedance	>100k <5	Ω pF
Clock jitter (integrated over 300Hz – 15KHz)	<1	Hz
Output high voltage	0.7V _{io} - V _{io}	V

Input signal amplitude follow VDDIO (1.8V or 3.3V)

External 37.4MHz X'TAL characteristics

Parameter	Specification	Units
Nominal frequency - F ₀	37.4	MHz
Frequency Tolerance - $\Delta F / F_0$ (At 25°C +/- 3°C)	+/- 5	ppm
Operation Temperature Range - Topr	-40 ~ + 85	°C
Freq. Stability(over operating temperature) - TC Ref. to 25°C	+/- 15	ppm
Load capacitance - CL	16	pF
Equivalent Series Resistance – ESR	Max. 60	Ω
Drive Level - DL	Typ. 50, Max. 100	μ W
Insulation resistance – IR At 100Vdc	Min. 500	M Ω

8. Host Interface Timing Diagram

8.1 Power-up Sequence Timing Diagram

The module has signals that allow the host to control power consumption by enabling or disabling the Bluetooth, WLAN and internal regulator blocks. These signals are described below.

Additionally, diagrams are provided to indicate proper sequencing of the signals for various operating states. The timing value indicated are minimum required values: longer delays are also acceptable.

- **WL_REG_ON:** Used by the PMU to power up or power down the internal regulators used by the WLAN section. When this pin is high, the regulators are enabled and the WLAN section is out of reset. When this pin is low the WLAN section is in reset.
- **BT_REG_ON:** Used by the PMU to power up or power down the internal regulators used by the BT section. Low asserting reset for Bluetooth. This pin has no effect on WLAN and does not control any PMU functions. This pin must be driven high or low (not left floating).

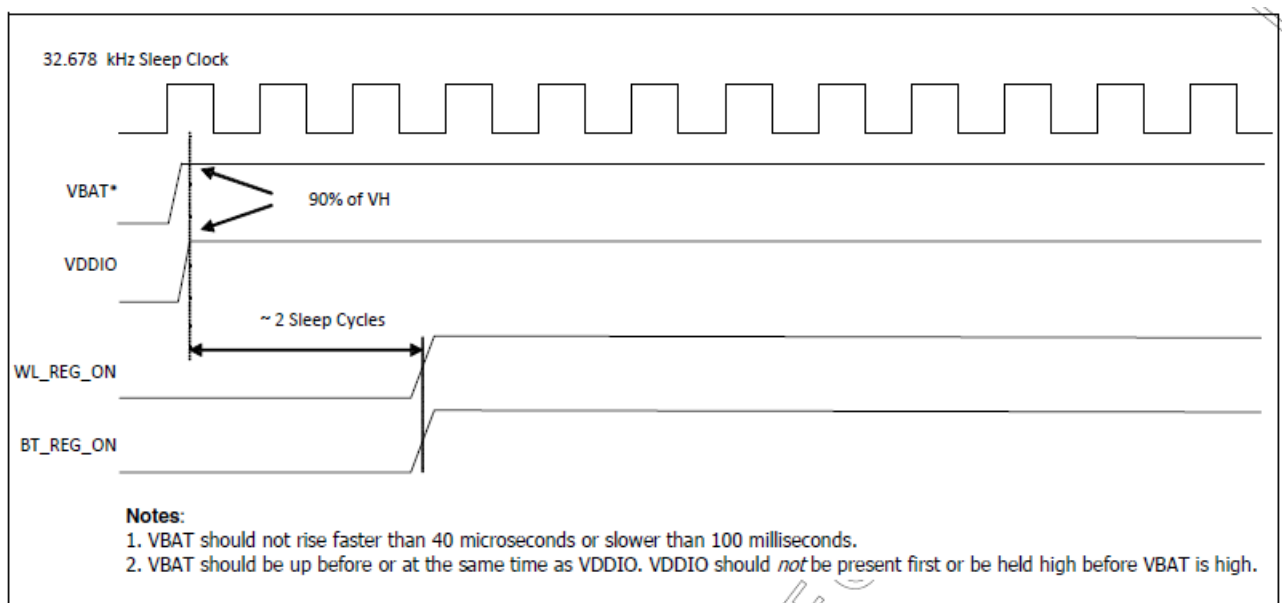

WLAN=ON, Bluetooth=ON

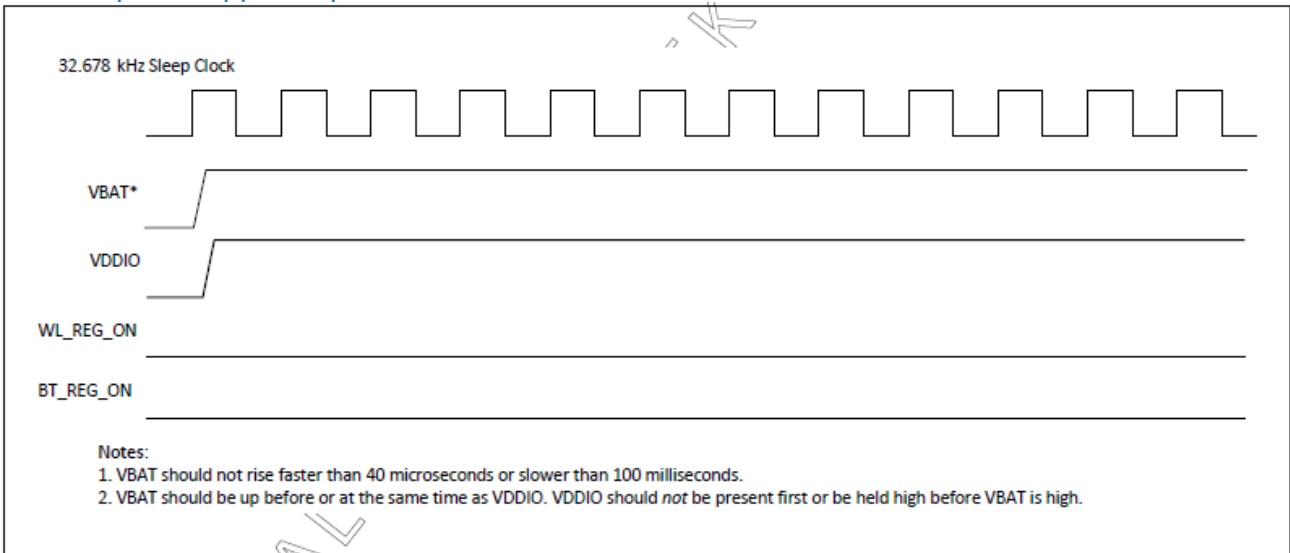

WLAN=OFF, Bluetooth=OFF

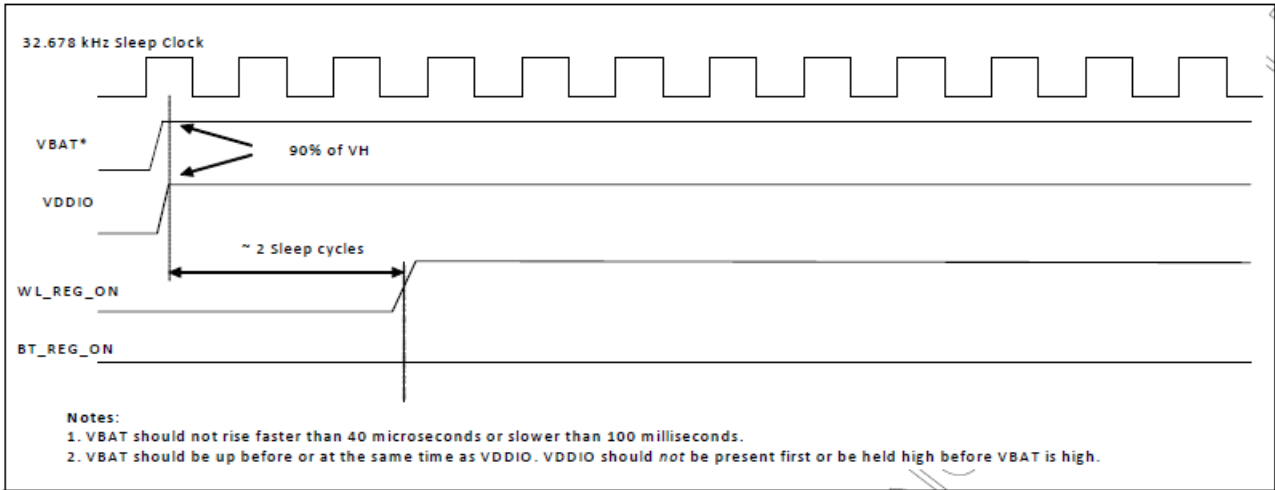

WLAN=ON, Bluetooth=OFF

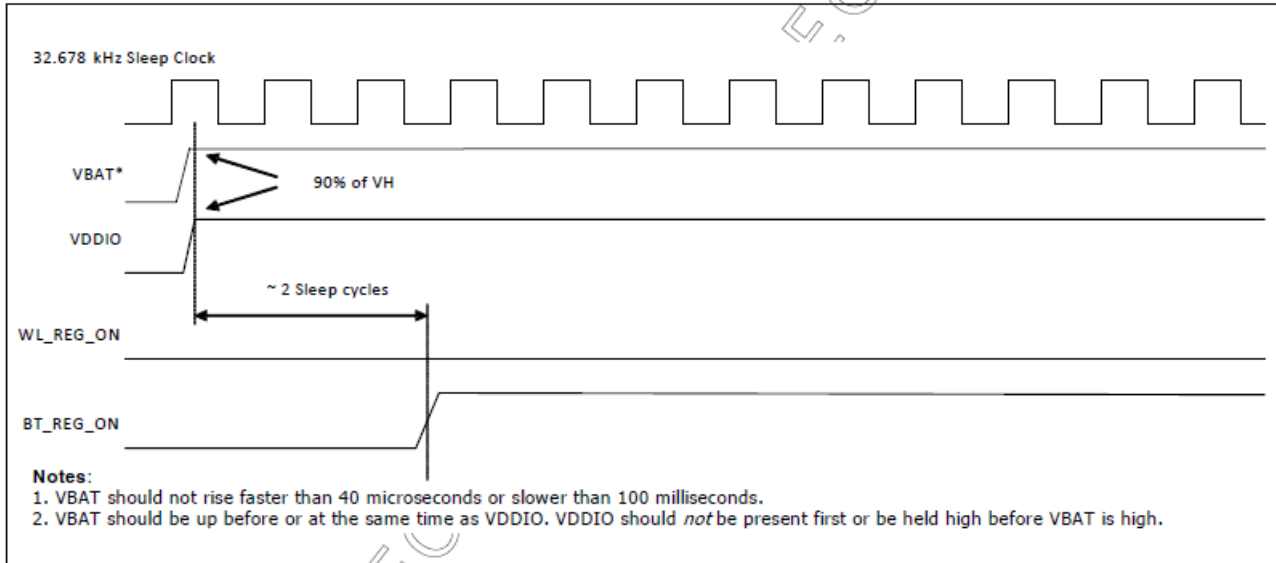

WLAN=OFF, Bluetooth=ON



8.2 SDIO Interface Description

The module supports SDIO version 3.0 for all 1.8V 4-bit UHSI speeds: SDR50(100 Mbps),SDR104(208MHz) and DDR50(50MHz, dual rates) in addition to the 3.3V default speed(25MHz) and high speed (50 MHz). It has the ability to stop the SDIO clock and map the interrupt signal into a GPIO pin. This 'out-of-band' interrupt signal notifies the host when the WLAN device wants to turn on the SDIO interface. The ability to force the control of the gated clocks from within the WLAN chip is also provided.

- Function 0 Standard SDIO function (Max BlockSize / ByteCount = 32B)
- Function 1 Backplane Function to access the internal System On Chip (SOC) address space (Max BlockSize / ByteCount = 64B)
- Function 2 WLAN Function for efficient WLAN packet transfer through DMA (Max BlockSize/ByteCount=512B)

SDIO Pin Description

SD 4-Bit Mode	
DATA0	Data Line 0
DATA1	Data Line 1 or Interrupt
DATA2	Data Line 2 or Read Wait
DATA3	Data Line 3
CLK	Clock
CMD	Command Line



8.3 SDIO Default Mode Timing Diagram

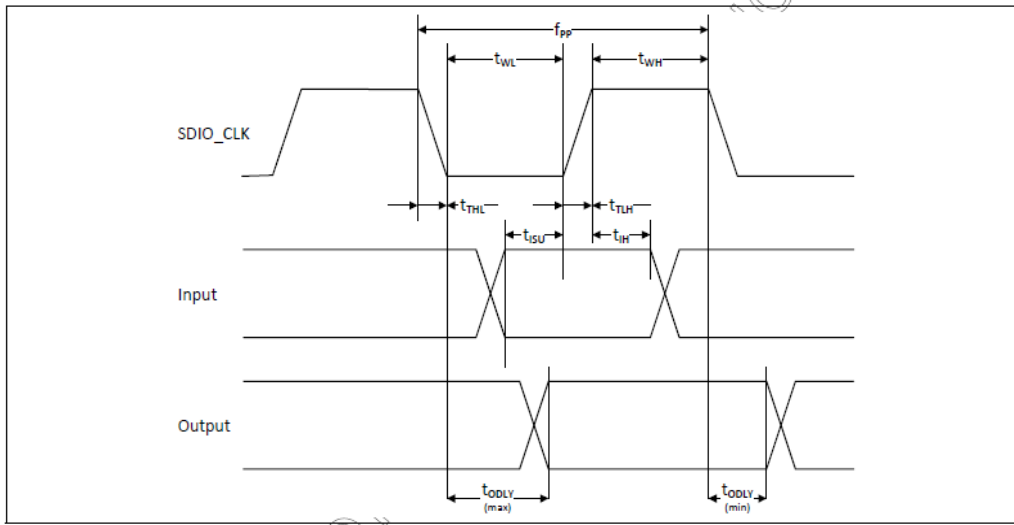

Parameter	Symbol	Minimum	Typical	Maximum	Unit
SDIO CLK (All values are referred to minimum VIH and maximum VIL^b)					
Frequency – Data Transfer mode	f_{PP}	0	–	25	MHz
Frequency – Identification mode	f_{OD}	0	–	400	kHz
Clock low time	t_{WL}	10	–	–	ns
Clock high time	t_{WH}	10	–	–	ns
Clock rise time	t_{TLH}	–	–	10	ns
Clock low time	t_{THL}	–	–	10	ns
Inputs: CMD, DAT (referenced to CLK)					
Input setup time	t_{ISU}	5	–	–	ns
Input hold time	t_{IH}	5	–	–	ns
Outputs: CMD, DAT (referenced to CLK)					
Output delay time – Data Transfer mode	t_{ODLY}	0	–	14	ns
Output delay time – Identification mode	t_{ODLY}	0	–	50	ns

a. Timing is based on $CL \leq 40pF$ load on CMD and Data.
 b. $\min(V_{ih}) = 0.7 \times V_{DDIO}$ and $\max(V_{il}) = 0.2 \times V_{DDIO}$.



8.4 SDIO High Speed Mode Timing Diagram

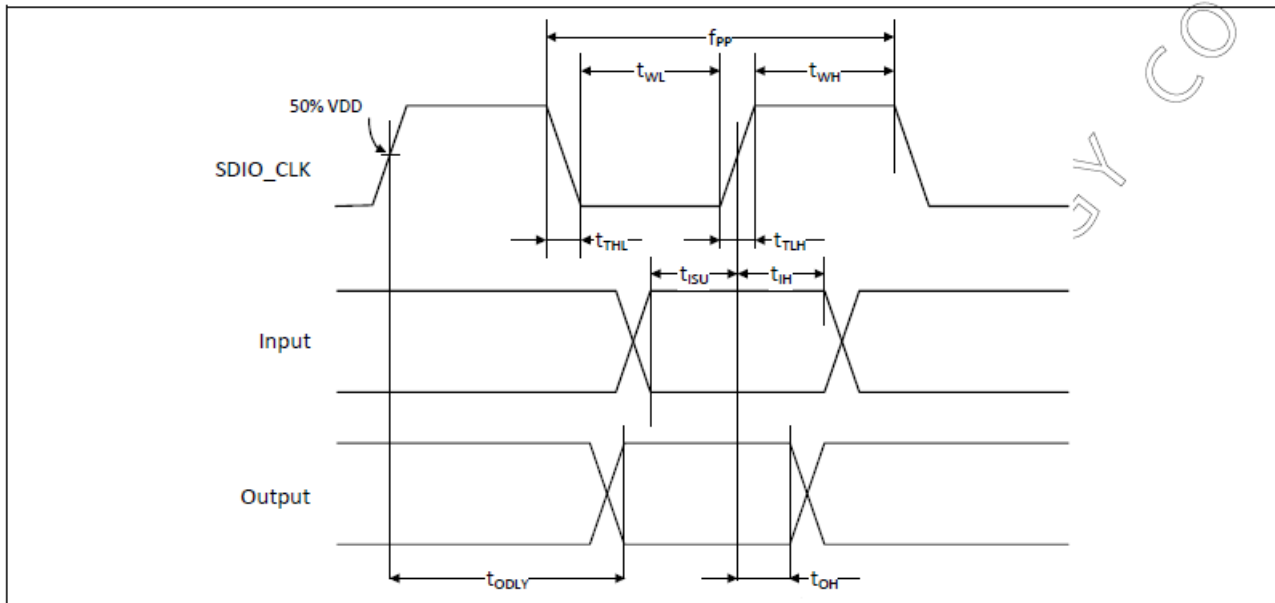

Parameter	Symbol	Minimum	Typical	Maximum	Unit
SDIO CLK (all values are referred to minimum VIH and maximum VIL^b)					
Frequency – Data Transfer Mode	f _{PPP}	0	–	50	MHz
Frequency – Identification Mode	f _{OD}	0	–	400	kHz
Clock low time	t _{WL}	7	–	–	ns
Clock high time	t _{WH}	7	–	–	ns
Clock rise time	t _{TLH}	–	–	3	ns
Clock low time	t _{THL}	–	–	3	ns
Inputs: CMD, DAT (referenced to CLK)					
Input setup Time	t _{ISU}	6	–	–	ns
Input hold Time	t _{IH}	2	–	–	ns
Outputs: CMD, DAT (referenced to CLK)					
Output delay time – Data Transfer Mode	t _{ODLY}	–	–	14	ns
Output hold time	t _{OH}	2.5	–	–	ns
Total system capacitance (each line)	CL	–	–	40	pF

a. Timing is based on CL ≤ 40 pF load on CMD and Data.

b. min(V_{Ih}) = 0.7 × VDDIO and max(V_{Il}) = 0.2 × VDDIO.

8.5 SDIO Bus Timing Specifications in SDR Modes

Clock timing(SDR Modes)

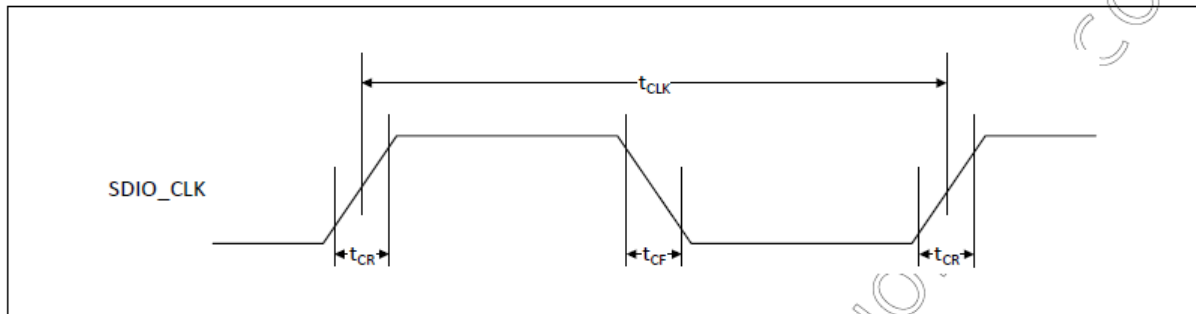

Parameter	Symbol	Minimum	Maximum	Unit	Comments
-	t_{CLK}	40	-	ns	SDR12 mode
		20	-	ns	SDR25 mode
		10	-	ns	SDR50 mode
		4.8	-	ns	SDR104 mode
-	t_{CR}, t_{CF}	-	$0.2 \times t_{CLK}$	ns	$t_{CR}, t_{CF} < 2.00$ ns (max) @100 MHz, $C_{CARD} = 10$ pF $t_{CR}, t_{CF} < 0.96$ ns (max) @208 MHz, $C_{CARD} = 10$ pF
Clock duty	-	30	70	%	-

SDIO Bus Input timing (SDR Modes)

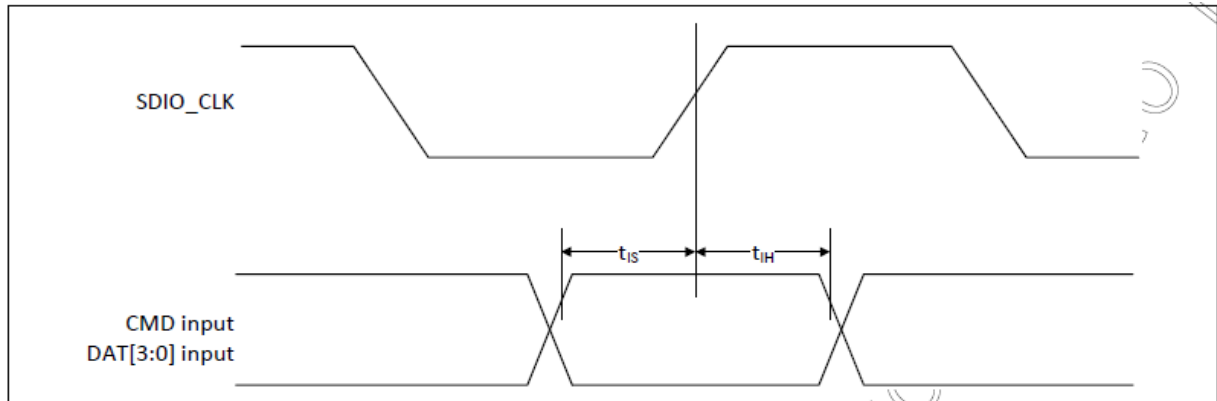

Symbol	Minimum	Maximum	Unit	Comments
SDR104 Mode				
t_{IS}	1.4	-	ns	$C_{CARD} = 10$ pF, VCT = 0.975V
t_{IH}	0.80	-	ns	$C_{CARD} = 5$ pF, VCT = 0.975V
SDR50 Mode				
t_{IS}	3.00	-	ns	$C_{CARD} = 10$ pF, VCT = 0.975V
t_{IH}	0.80	-	ns	$C_{CARD} = 5$ pF, VCT = 0.975V

SDIO Bus output timing (SDR Modes up to 100MHz)

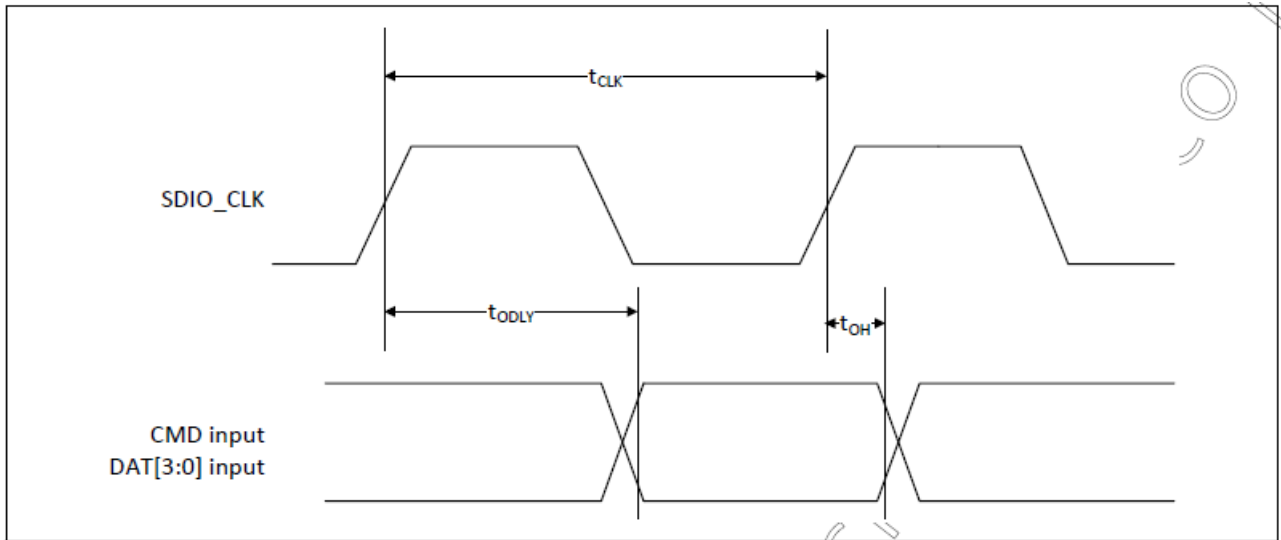

Symbol	Minimum	Maximum	Unit	Comments
t_{ODLY}	–	7.5	ns	$t_{CLK} \geq 10$ ns $C_L = 30$ pF using driver type B for SDR50
t_{ODLY}	–	14.0	ns	$t_{CLK} \geq 20$ ns $C_L = 40$ pF using for SDR12, SDR25
t_{OH}	1.5	–	ns	Hold time at the t_{ODLY} (min) $C_L = 15$ pF

Card output timing (SDR Modes 100MHz to 208MHz)

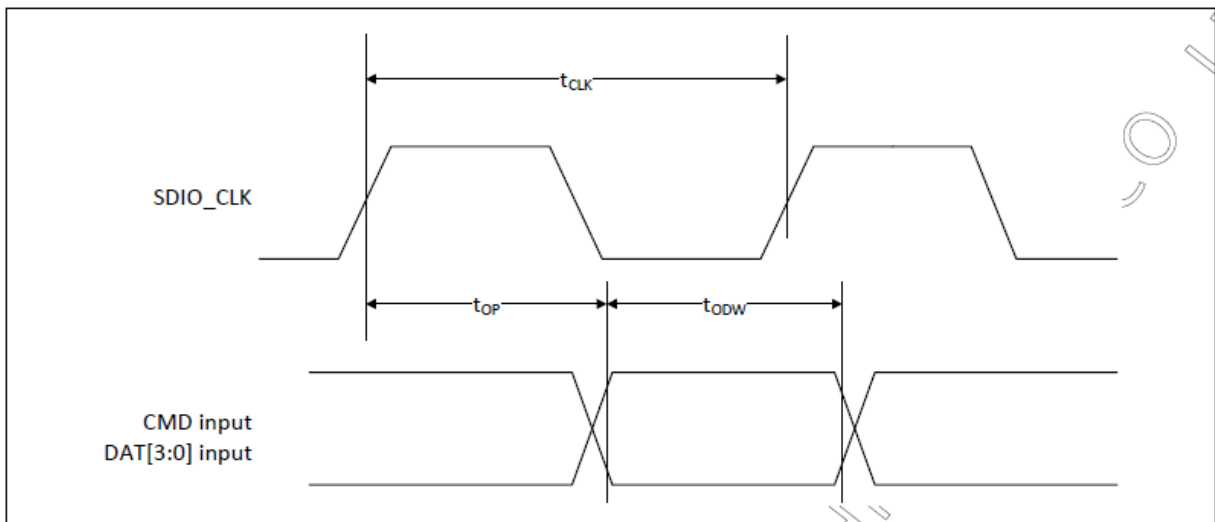

Symbol	Minimum	Maximum	Unit	Comments
t_{OP}	0	2	UI	Card output phase
Δt_{OP}	-350	+1550	ps	Delay variation due to temp change after tuning
t_{ODW}	0.60	–	UI	$t_{ODW} = 2.88$ ns @ 208 MHz

- $\Delta t_{OP} = +1550$ ps for junction temperature of $\Delta t_{OP} = 90$ degrees during operation
- $\Delta t_{OP} = -350$ ps for junction temperature of $\Delta t_{OP} = -20$ degrees during operation
- $\Delta t_{OP} = +2600$ ps for junction temperature of $\Delta t_{OP} = -20$ to $+125$ degrees during operation



Δt_{OP} Consideration for Variable Data Window (SDR 104 Mode)

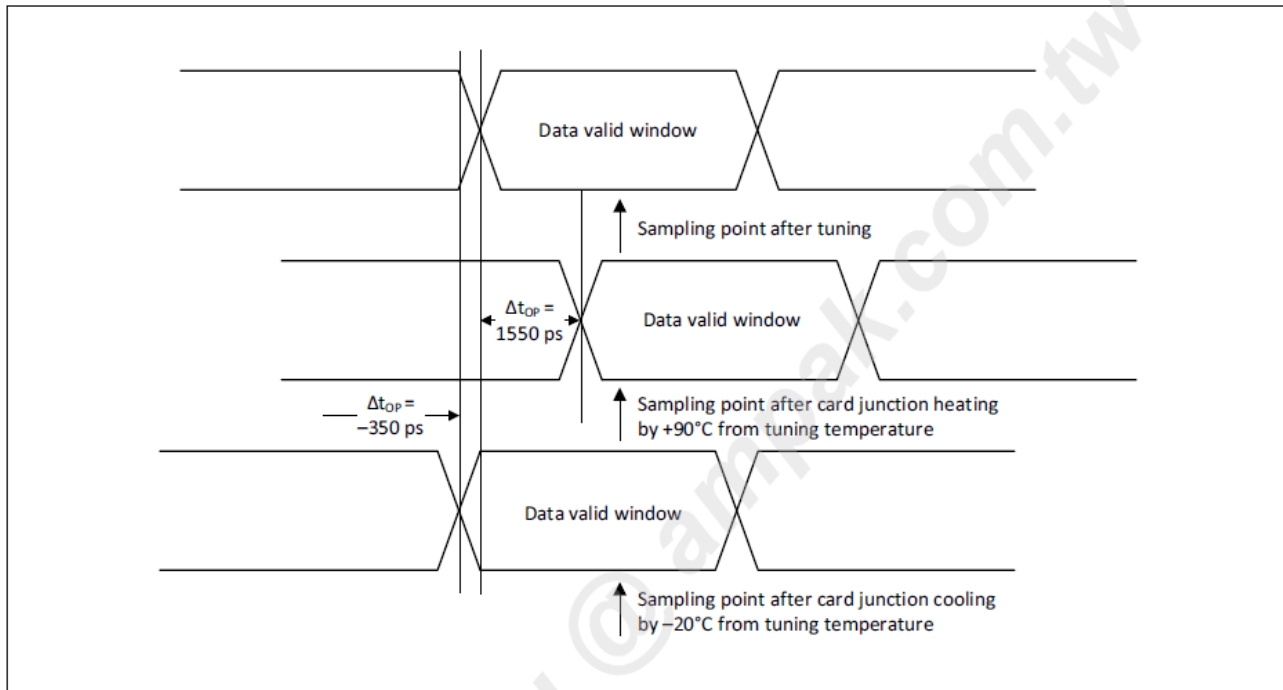

8.6 SDIO Bus Timing Specifications in DDR50 Mode

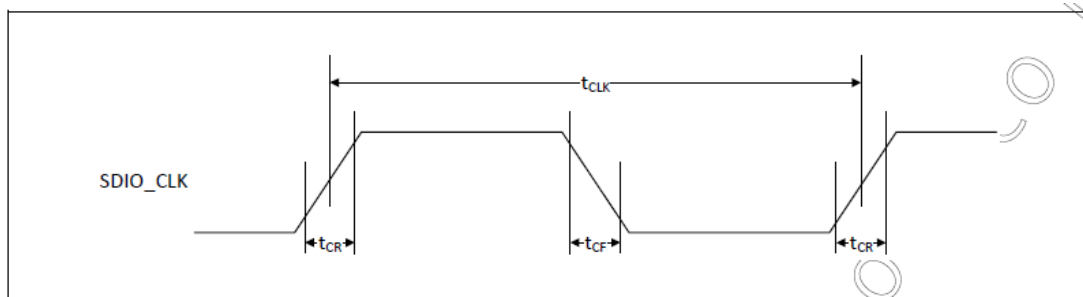

Parameter	Symbol	Minimum	Maximum	Unit	Comments
-	t_{CLK}	20	-	ns	DDR50 mode
-	t_{CR}, t_{CF}	-	$0.2 \times t_{CLK}$	ns	$t_{CR}, t_{CF} < 4.00$ ns (max) @50 MHz, $C_{CARD} = 10$ pF
Clock duty	-	45	55	%	-



Data Timing

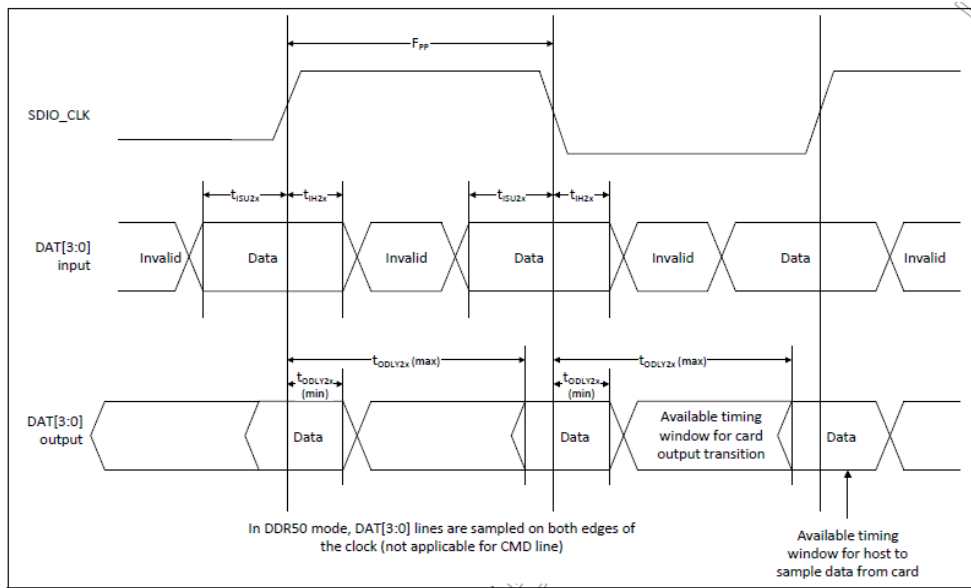

Parameter	Symbol	Minimum	Maximum	Unit	Comments
Input CMD					
Input setup time	t_{ISU}	6	–	ns	$C_{CARD} < 10 \text{ pF}$ (1 Card)
Input hold time	t_{IH}	0.8	–	ns	$C_{CARD} < 10 \text{ pF}$ (1 Card)
Output CMD					
Output delay time	t_{ODLY}	–	13.7	ns	$C_{CARD} < 30 \text{ pF}$ (1 Card)
Output hold time	t_{OH}	1.5	–	ns	$C_{CARD} < 15 \text{ pF}$ (1 Card)
Input DAT					
Input setup time	t_{ISU2x}	3	–	ns	$C_{CARD} < 10 \text{ pF}$ (1 Card)
Input hold time	t_{IH2x}	0.8	–	ns	$C_{CARD} < 10 \text{ pF}$ (1 Card)
Output DAT					
Output delay time	t_{ODLY2x}	–	7.5	ns	$C_{CARD} < 25 \text{ pF}$ (1 Card)
Output hold time	t_{ODLY2x}	1.5	–	ns	$C_{CARD} < 15 \text{ pF}$ (1 Card)



9. Recommended Reflow Profile

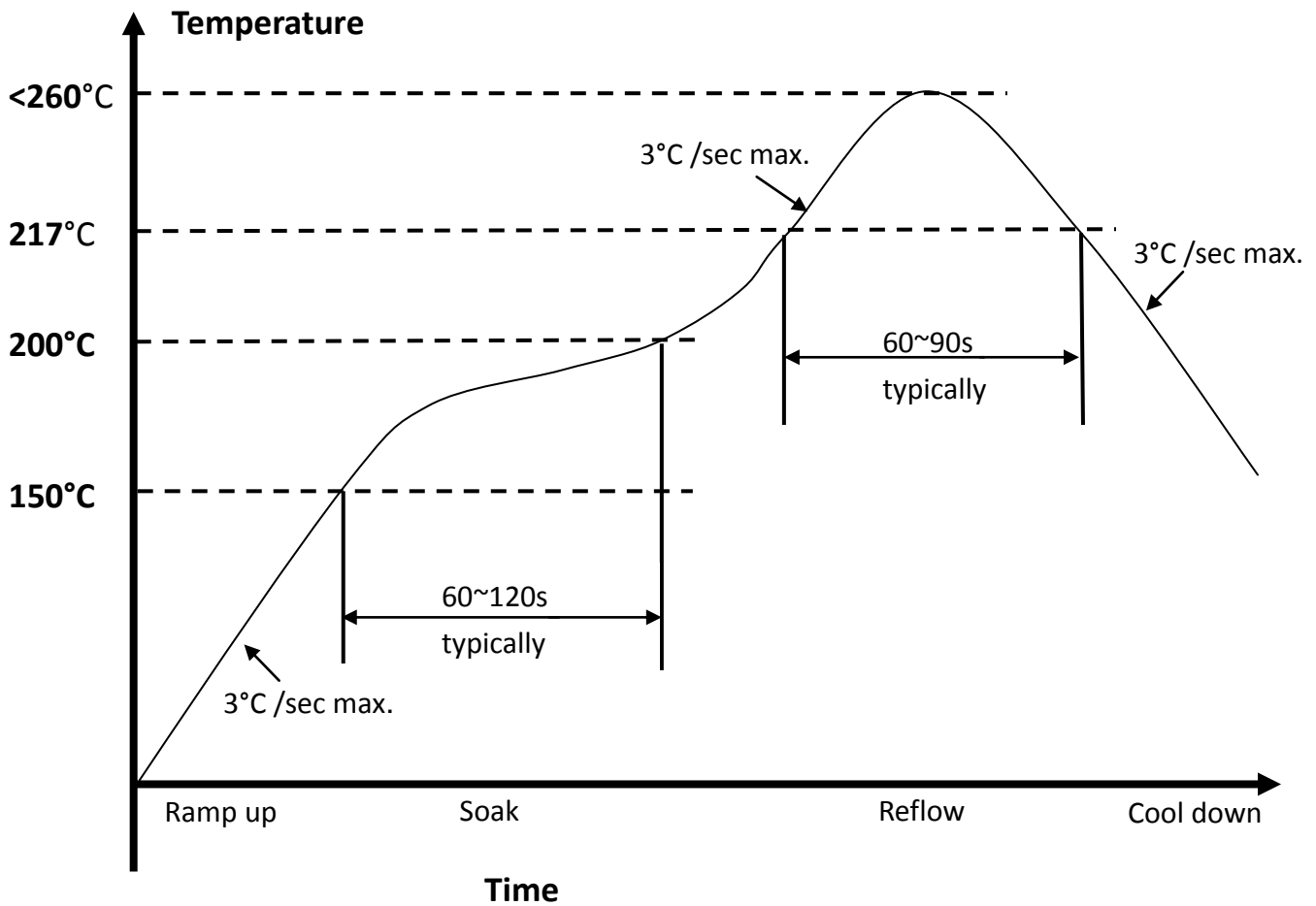

1. Referred to IPC/JEDEC standard
2. Peak Temperature : $<260^{\circ}\text{C}</math>$
3. Cycle of Reflow : 2 times max.
4. Adding Nitrogen (N_2) to implement 2000ppm or less of oxygen concentration during reflow process is recommended.
5. If the shelf time is exceeded, be sure baking step to remove the moisture from the component

10. Package Information

10.1 Label

Label A → Anti-static and humidity notice



Label B → MSL caution / Storage Condition

	Caution	LEVEL
	This bag contains MOISTURE-SENSITIVE DEVICES	
<p>1. Calculated shelf life in sealed bag: 12 months at <40°C and <90% relative humidity (RH)</p> <p>2. Peak package body temperature: _____ °C <small>If blank, see adjacent bar code label</small></p> <p>3. After bag is opened, devices that will be subjected to reflow solder or other high temperature process must be</p> <p>a) Mounted within: _____ hours of factory conditions <small>If blank, see adjacent bar code label</small></p> <p> ≤30°C/60% RH, or</p> <p>b) Stored per J-STD-033</p> <p>4. Devices require bake, before mounting, if:</p> <p>a) Humidity Indicator Card reads >10% for level 2a - 5a devices or >60% for level 2 devices when read at 23 ± 5°C</p> <p>b) 3a or 3b are not met</p> <p>5. If baking is required, refer to IPC/JEDEC J-STD-033 for bake procedure</p> <p>Bag Seal Date: _____ <small>If blank, see adjacent bar code label</small></p> <p style="text-align: center;"><small>Note: Level and body temperature defined by IPC/JEDEC J-STD-020</small></p>		

Label C → Inner box label .

PO:	_____
AMK DEVICE:	_____
PKG S/N:	9PKGYMMDDNNNNN
Model Name:	APXXXXXXXX (R3HF)
P/N:	99X-XXX-XXXXR
Quantity:	QQQQ
Date Code:	YYWW
Lot Code:	XXXXXXXX

Label D → Carton box label .

AMPAK Technology Inc.	
PO:	_____
AMK DEVICE:	_____
Model Name:	APXXXXXXXX (R3HF)
Part No.:	99X-XXX-XXXXR
Quantity:	QQQQ
Lot D/C:	XXXXXXXX YYWW QQQQ
Manufacture:	YYYYMM/DD



10.2 Dimension

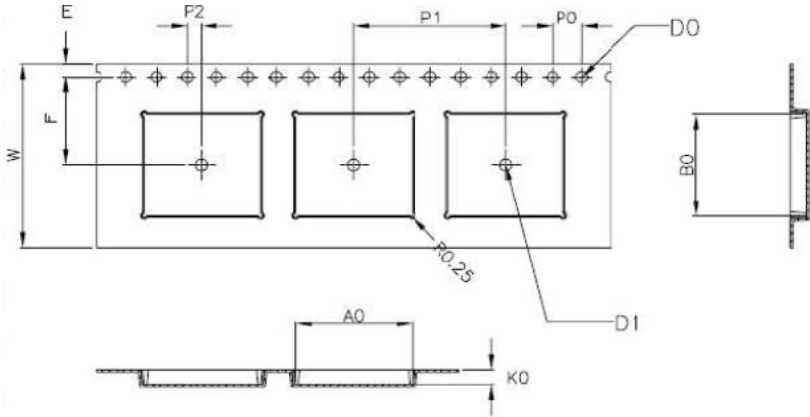
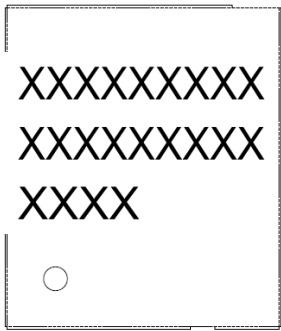

W	24.00±0.30
A0	15.30±0.10
B0	13.30±0.10
K0	2.00±0.10
E	1.75±0.10
F	11.50±0.10
P0	4.00±0.10
P1	20.00±0.10
P2	2.00±0.10
D0	1.50 ^{+0.10} / _{-0.00}
D1	∅1.50MIN

1. 10 sprocket hole pitch cumulative tolerance ±0.20.
2. Carrier camber is within 1 mm in 250 mm.
3. Material : Black Conductive Polystyrene Alloy.
4. All dimensions meet EIA-481-D requirements.
5. Thickness: 0.30±0.05mm.
6. Component load per 13" reel : 1000 pcs

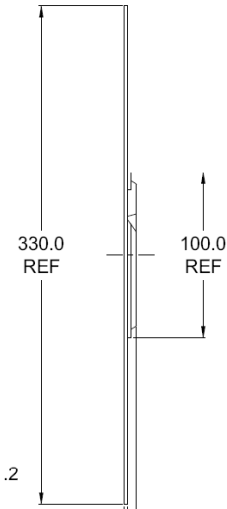
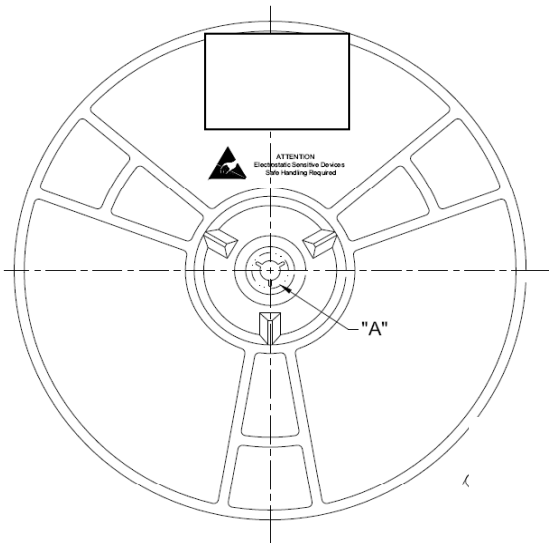

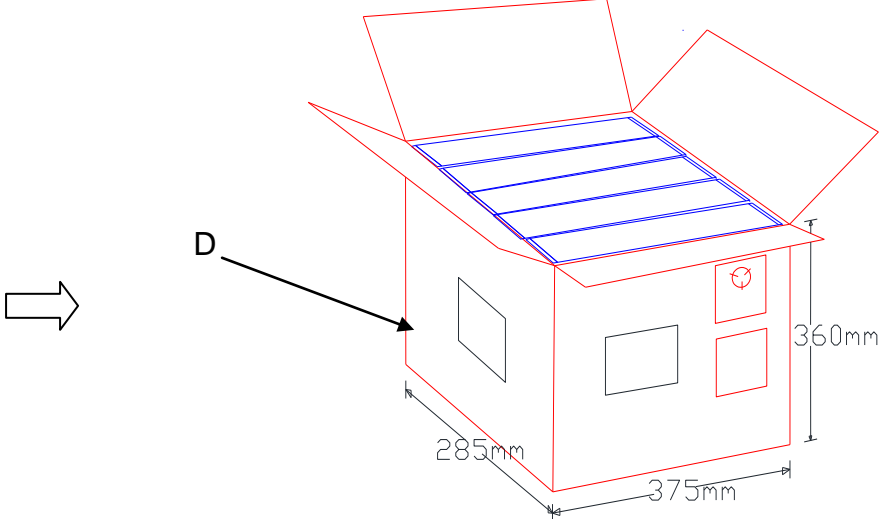
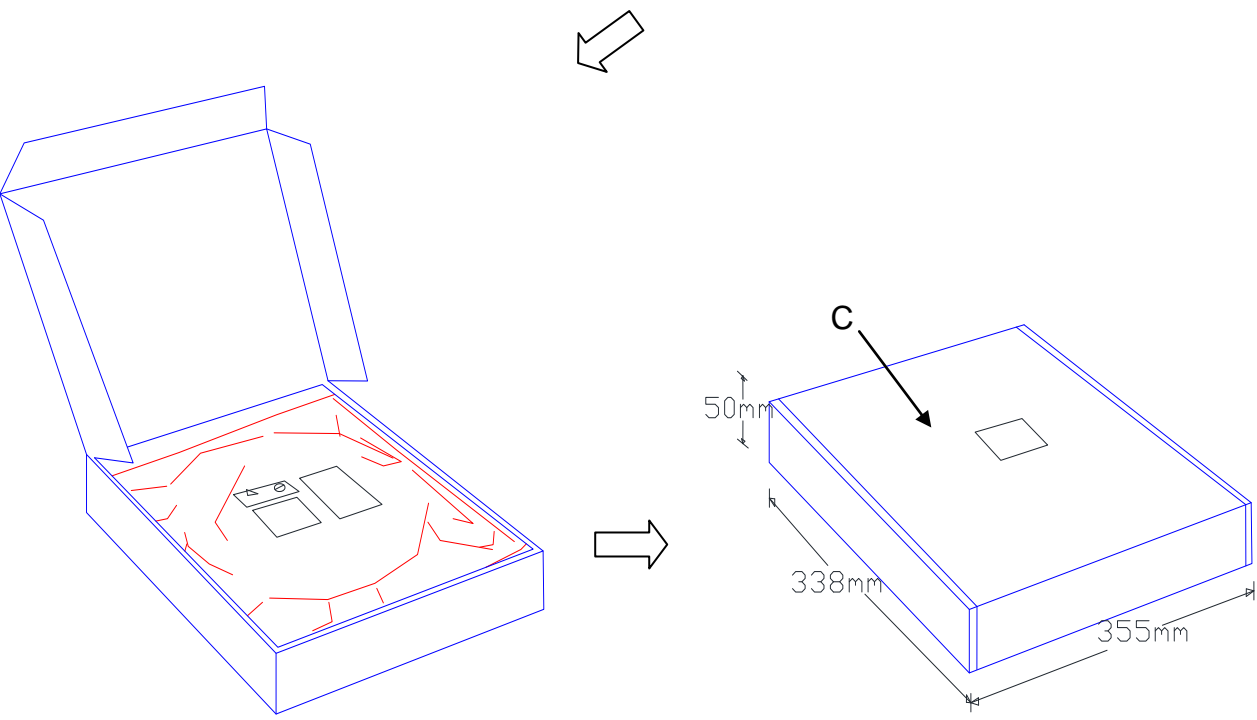
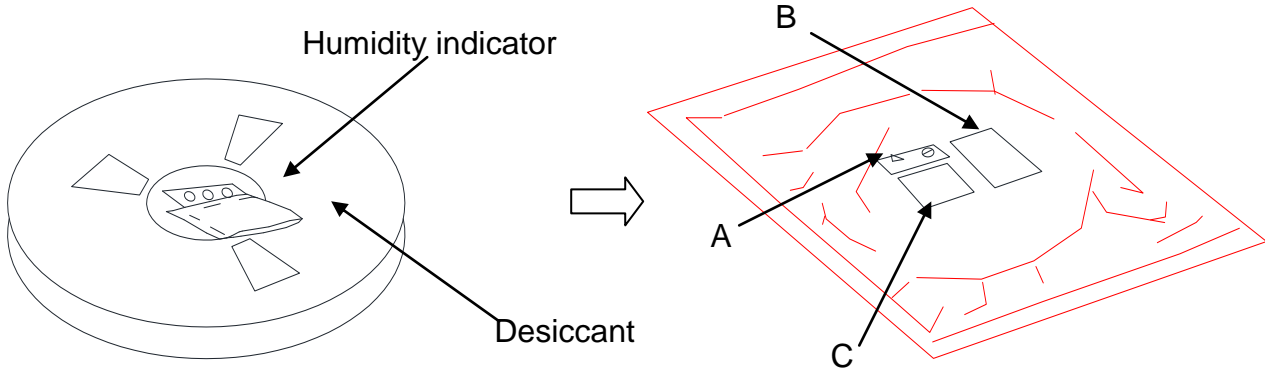

10.3 MSL Level / Storage Condition

	Caution This bag contains MOISTURE-SENSITIVE DEVICES	LEVEL <div style="border: 1px solid black; padding: 5px; display: inline-block;"> 4 </div>
		<small>If blank, see adjacent bar code label</small>
<p>1. Calculated shelf life in sealed bag: 12 months at $<40^{\circ}\text{C}$ and $<90\%$ relative humidity (RH)</p> <p>2. Peak package body temperature: <u>250</u> $^{\circ}\text{C}$ <small>If blank, see adjacent bar code label</small></p> <p>3. After bag is opened, devices that will be subjected to reflow solder or other high temperature process must be</p> <p>a) Mounted within: <u>72</u> hours of factory conditions <small>If blank, see adjacent bar code label</small></p> <p style="padding-left: 40px;">$\leq 30^{\circ}\text{C}/60\% \text{RH}$, or</p> <p>b) Stored per J-STD-033</p> <p>4. Devices require bake, before mounting, if:</p> <p>a) Humidity Indicator Card reads $>10\%$ for level 2a-5a devices or $>60\%$ for level 2 devices when read at $23 \pm 5^{\circ}\text{C}$</p> <p>b) 3a or 3b are not met.</p> <p>5. If baking is required, refer to IPC/JEDEC J-STD-033 for bake procedure.</p> <p>Bag Seal Date: _____ <small>If blank, see adjacent bar code label</small></p> <p style="text-align: center;">Note: Level and body temperature defined by IPC/JEDEC J-STD-020</p>		