

# Comchips

## KX6125 Module Data sheet



# KX6125

## Module Data sheet

Website: [www.comchips.com](http://www.comchips.com)

Customer Approval

Company \_\_\_\_\_

Title \_\_\_\_\_

Signature \_\_\_\_\_

Date \_\_\_\_\_

FTY \_\_\_\_\_

## Version Update Record

<b>Version</b>	<b>Date</b>	<b>Revision Content</b>	<b>Editorialstaff</b>
V1.0	2021/8/15	The first version	

# CONTENTS

<b>1 Overview</b> .....	<b>5</b>
1.1 Introduction .....	5
1.2 Features .....	5
1.3 Block Diagram .....	5
1.4 General Specification .....	6
1.5 DC Characteristics .....	7
<b>2 RF Specifications</b> .....	<b>8</b>
<b>3 Pin Assignments</b> .....	<b>9</b>
3.1 Pin Outline .....	9
3.2 Pin Definition .....	9
<b>4 Dimensions</b> .....	<b>10</b>
4.1 Module Picture .....	10
4.2 Module Physical Dimensions.....	10
<b>5 Reference Design</b> .....	<b>11</b>
5.1 WIFI RF Circuit reference pictures .....	11
5.2 USB interface electrical characteristics .....	11
<b>6 The Key Material List</b> .....	<b>12</b>
<b>7 Recommended Reflow Profile</b> .....	<b>12</b>
<b>8 Package Information</b> .....	<b>13</b>
8.1 Reel.....	13
8.2 Carrier Tape Detail .....	13
8.3 Packaging Detail.....	14
8.4 Moisture sensitivity .....	14

# 1 Overview

## 1.1 Introduction

KX6125 is a WLAN 11n USB module, which fully supports the features and Functional compliance of IEEE 802.11n,e and i standards. It supports up to 150Mbps high-speed wireless network connections.

It is designed to provide excellent performance with low power Consumption and enhance the advantages of robust system and cost-effective. It is targeted at competitive superior performance, better power Management applications.

## 1.2 Features

- Operates in 2.4 GHz frequency bands
- 1x1 MIMO technology improves effective throughput and range existing 802.11 b/g products
- Data rates: up to 150Mbps
- 802.11e-compatible bursting and I standards
- BPSK, QPSK, 16 QAM, 64 QAM modulation schemes
- WEP, TKIP, and AES, WPA, WPA2 hardware encryption schemes

### 1.3 Block Diagram

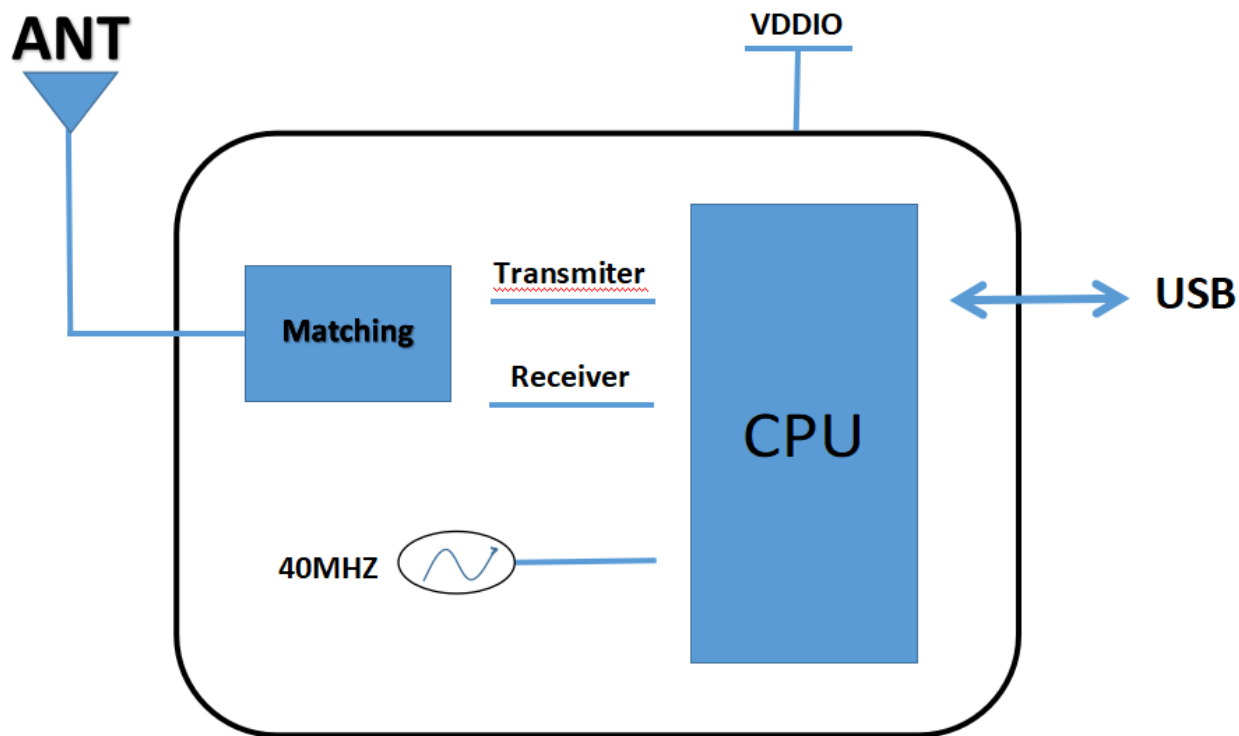

### 1.4 General Specification

Model Name	KX6125
Product Description	Support WIFI:IEEE802.11 11b/g/n
Dimension	L x W x H: 12 x 13 x 1.6mm
Wi-Fi Interface	Support USB2.0
BT interface	N/C
Operating temperature	0 to +70° C
Storage temperature	-55°C to 125°C
RoHS	All hardware components are fully compliant with EU RoHS directive

## 1.5 DC Characteristics



### Power Supply Characteristics

Symbol	Parameter	Minimum	Typical	Maximum	Units
VDD33	3.3V Supply Voltage	3.0	3.3	3.6	V
VDD12	1.2V Core Supply Voltage	1.10	1.20	1.32	V
IDD33	3.3V Rating Current	/	/	600	mA

## 2 RF Specification



Features	Description		
WLAN Standard	WLAN 11b/g/n		
Frequency Range	2.412 ~ 2.484 GHz		
Data Transfer Rate	1,2,5.5,6,11,12,18,22,24,30,36,48,54,60,90,120 and maximum of 150Mbps		
Modulation Method	DSSS,DBPSK, DQPSK, CCK and OFDM (BPSK/QPSK/16-QAM/64-QAM)		
Number of Channel	WiFi 2.4GHz: 11: (Ch. 1-11) – United States; 13: (Ch. 1-13) –Europe ; 14: (Ch. 1-14) – Japan		
OS Support	Windows 2000,XP32-64,Vista 32/64,Win7 32/64, Linux,Mac, Android,WIN CE		
<b>2.4G Transmitter Specifications</b>			
TX Rate	TX Power	TX Power Tolerance	EVM
802.1 1b @ 11 Mbps	17dBm	±2dBm	≤-13dB
802.11g@54Mbps	14dBm	±2dBm	≤-25dB
802.11n@BW20_MC S7	13dBm	±2dBm	≤-28dB
802.11n@BW40_MC S7	13dBm	±2dBm	≤-28dB
<b>2.4G Receiver Specifications</b>			
RX Rate	Min Input Level(Typ)	Max Input Level(Typ)	PER
802.1 1b @ 11 Mbps	-85dBm	-85dBm	8%
802.11g@54Mbps	-68dBm	-68dBm	10%
802.11n@BW20_MC S7	-66dBm	-66dBm	10%
802.11n@BW40_MC S7	-65dBm	-65dBm	10%

### 3 Pin Assignments

#### 3.1 Pin Outline

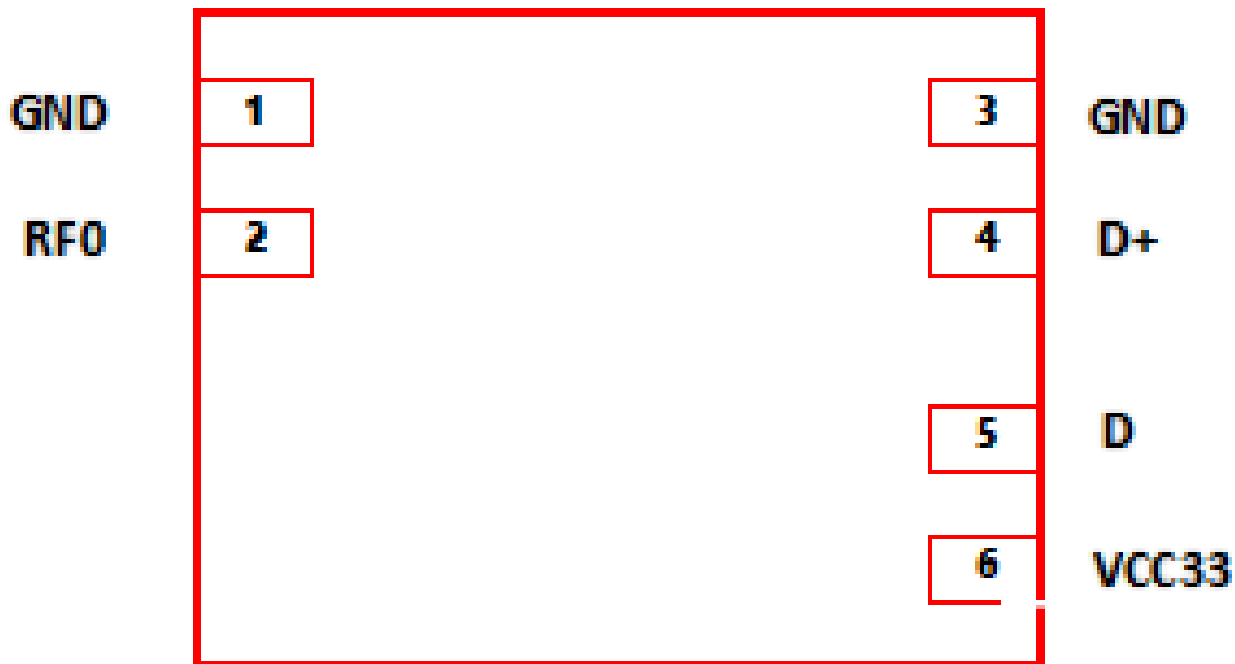

#### 3.2 Pin Definition

Pin	Definition	Description
1	GND	Grond
2	RF0	WLAN/BT RF TX/RX signal0
3	GND	Grond
4	D+	High-Speed USB D+ Signal
5	D-	High-Speed USB D- Signal
6	VCC33	VDD3.3V for Digital IO

## 4 Dimensions

### 4.1 Module Picture

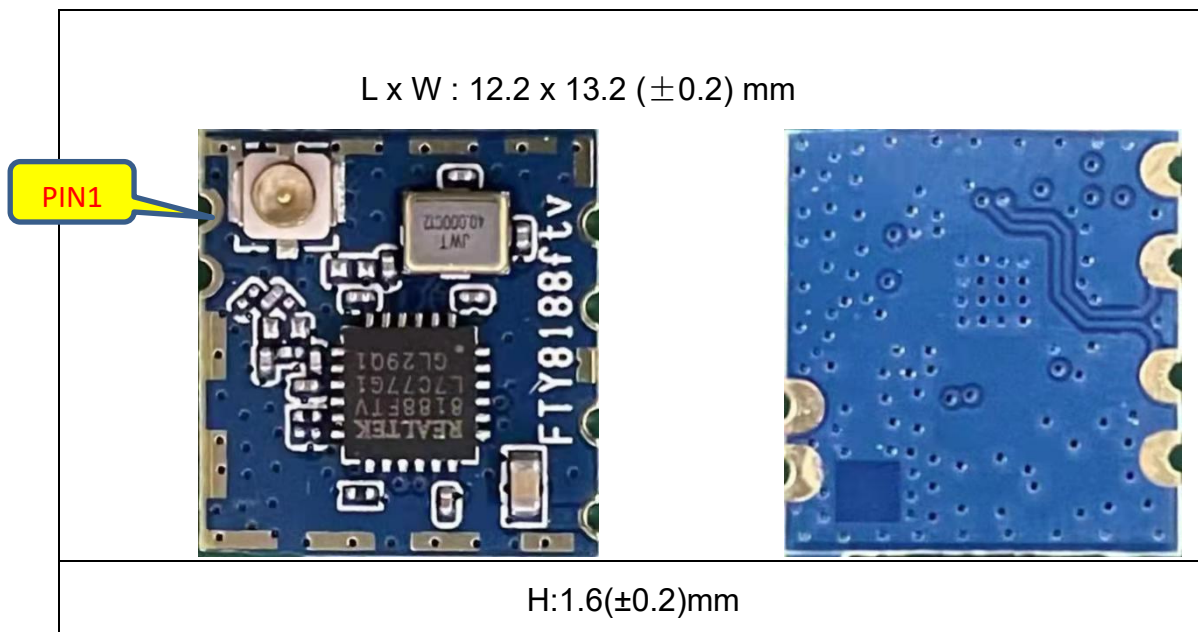

### 4.2 Module Physical Dimensions

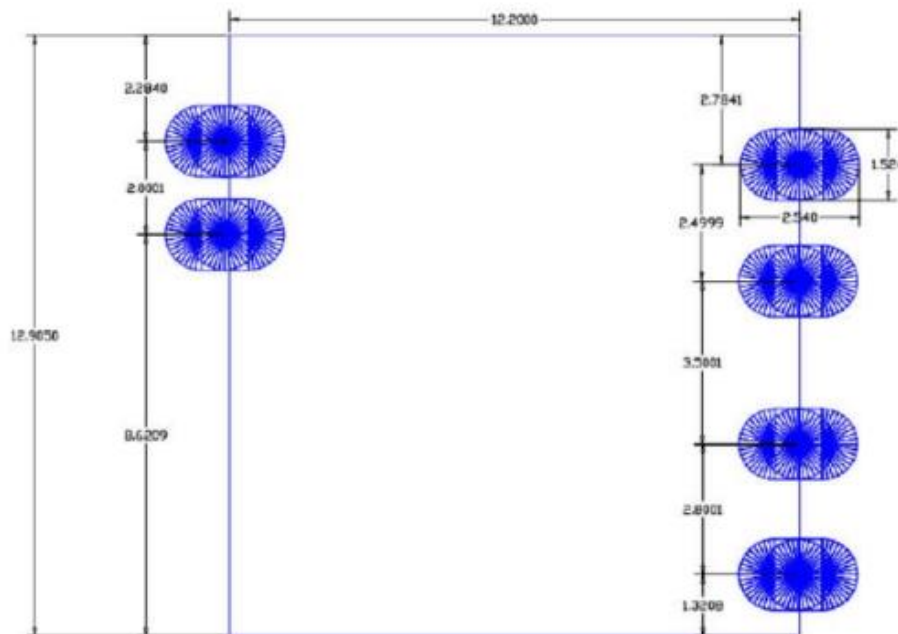

(Unit: mm)

< TOP VIEW >

## 5 Reference Design

### 5.1 WIFI RF Circuit reference pictures

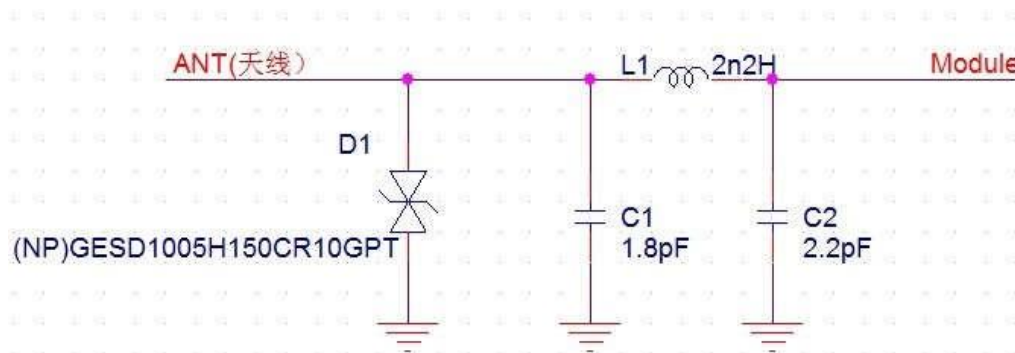

1. Above the dotted box part of the antenna matching is needed, the actual antenna matching electronic parameters shall prevail.
2. For RF part layout to do 50 ohm impedance. can't go on 90° of layout .The line length can't more than 20 mm.

Note: Please be sure to add a TVS tube at the end of the welding antenna to prevent ESD static electricity from damaging the WIFI module (as shown in the reference circuit above).

### 5.2 USB interface electrical characteristic

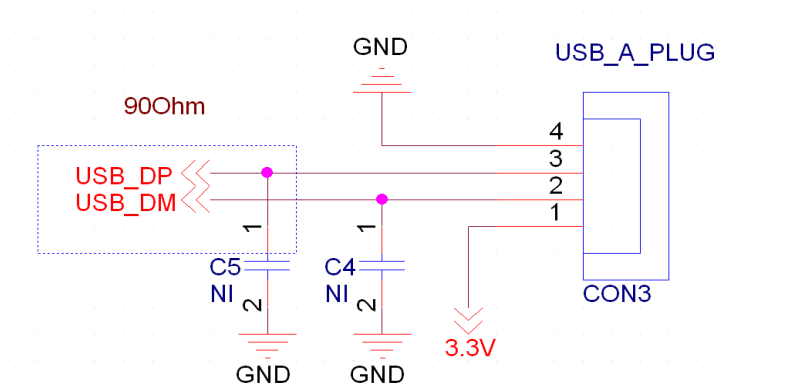

#### Note:

1. USB data cable need to do 90Ohm impedance
2. It is recommended to keep a power switch at the input end of the power supply. Each time the card is opened or closed, it can be used for power on and power off. WIFI can be reset, so that there will be no error phenomenon of not opening WIFI

## 6 The Key Material List

No.	Parts	Specification	Manufacturer	Note
1	Chipset	RTL8188FTV-VC-CG	Realtek Semiconductor Corp	
2	PCB	KX8188FTV_H40	Shenzhen xiangyu circuit co., LTD	
3	PCB	KX8188FTV_H40	Shenzhen Kexiang Precision Circuit Technology Co., LTD	
4	Crystal oscillator	3225 40MHZ 12PF +/- 10PPM -20~+85°C	hefei jing wei Electronics Co. Ltd.	
5	Crystal oscillator	3225 40MHZ 12PF +/- 10PPM -20+85°C 川晶	ZhejiangLanjingxin Microelectronics Co., LTD	

## 7 Recommended Reflow Profile

Referred to IPC/JEDEC standard.

Peak Temperature : <250°C

Number of Times : ≤2 times

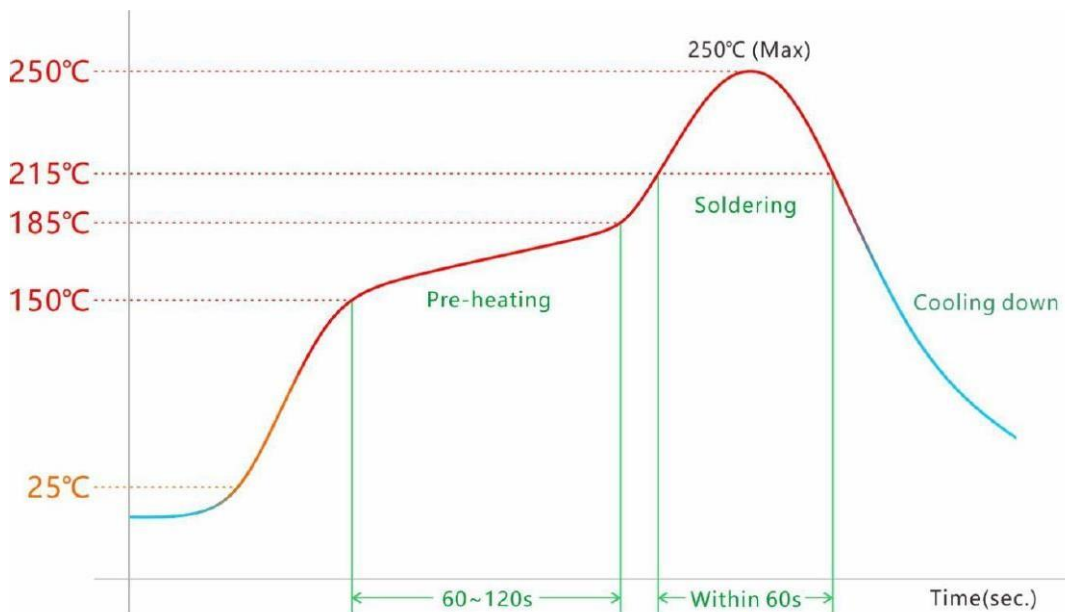

## 8 Package Information

### 8.1 Reel

A roll of 2000pcs

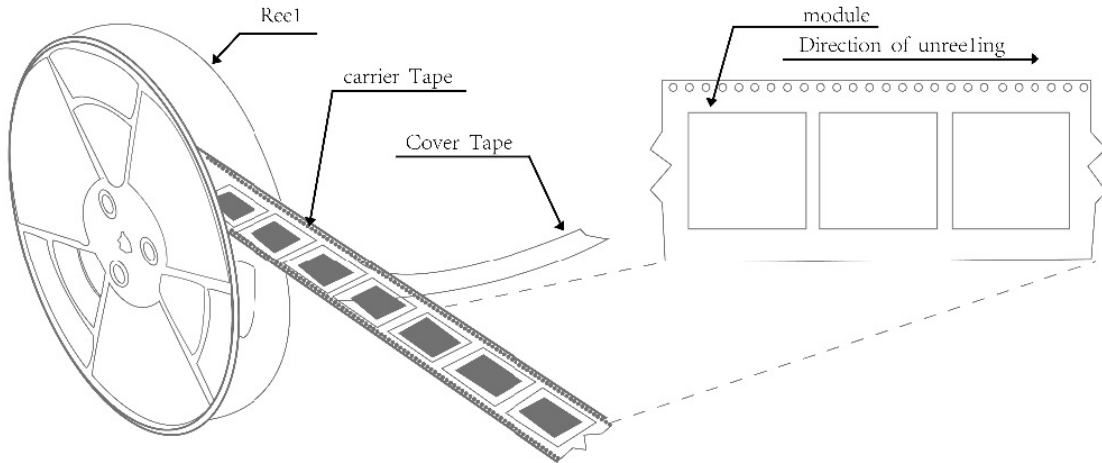

### 8.2 Carrier Tape Detail

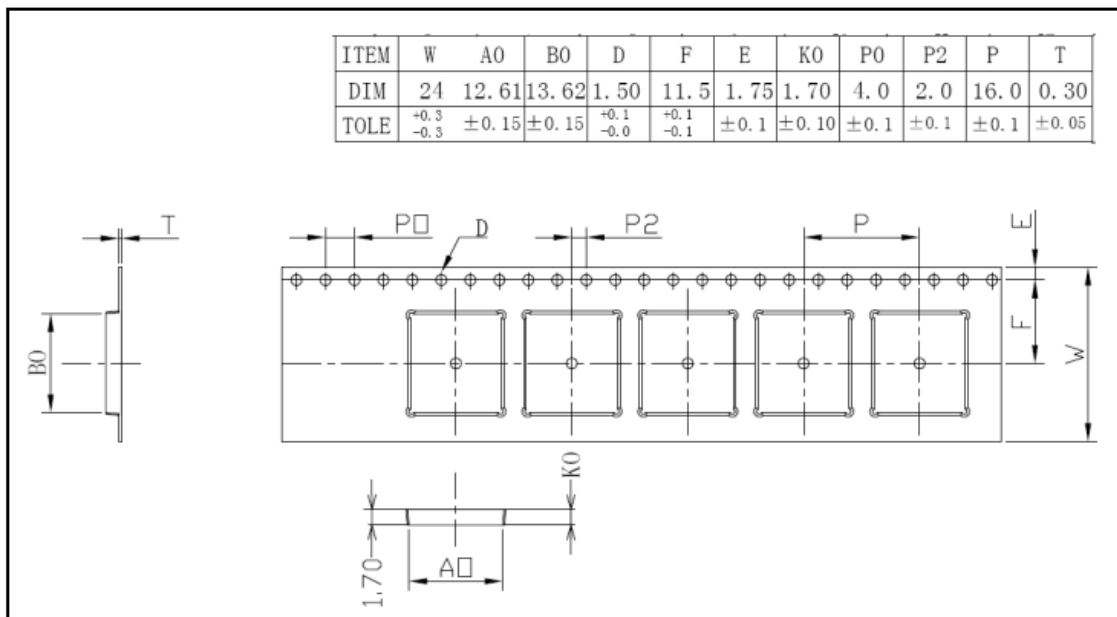

### 8.3 Packaging Detail

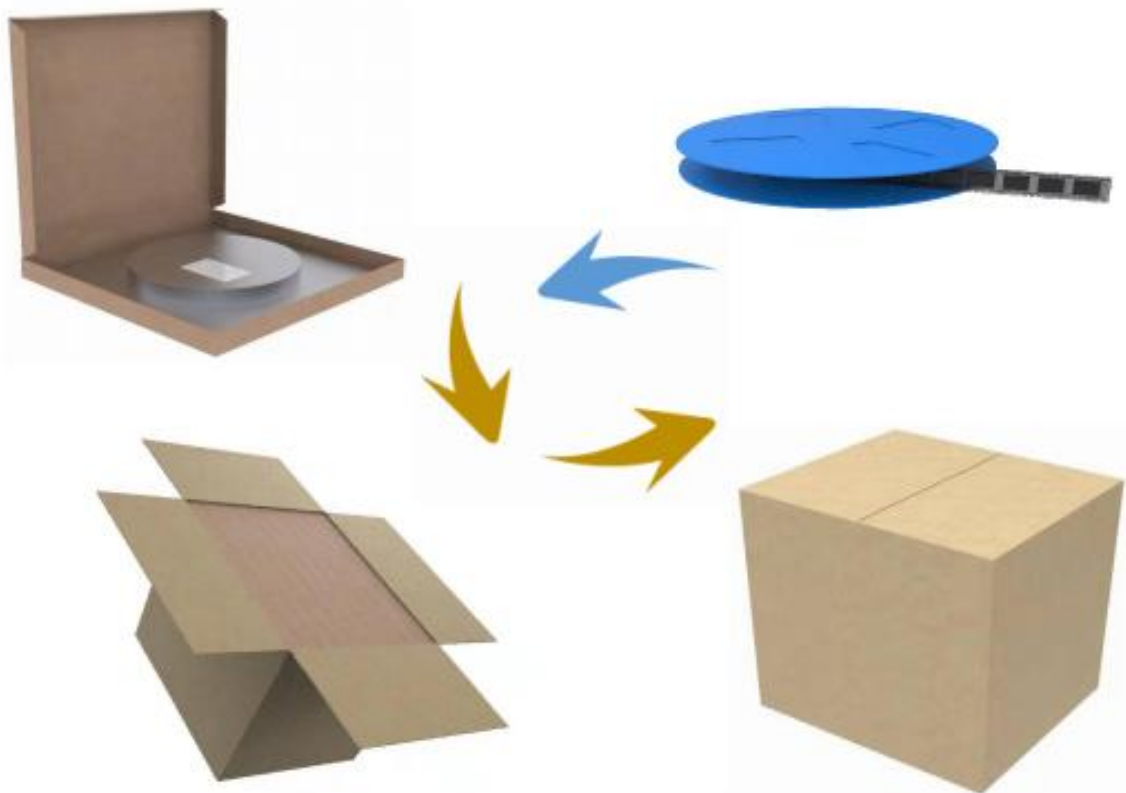

### 8.4 Moisture sensitivity

The Modules is a Moisture Sensitive Device level 3, in according with standard IPC/JEDEC J-STD-020, take care all the relatives requirements for using this kind of components.

Moreover, the customer has to take care of the following conditions:

- a) Calculated shelf life in sealed bag: 12 months at  $<40^{\circ}\text{C}$  and  $<90\%$  relative humidity (RH).
- b) Environmental condition during the production:  $30^{\circ}\text{C}$  /  $60\%$  RH according to IPC/JEDEC J-STD-033A paragraph 5.
- c) The maximum time between the opening of the sealed bag and the reflow process must be 168 hours if condition b) "IPC/JEDEC J-STD-033A paragraph 5.2" is respected
- e) Baking is required if conditions b) or c) are not respected
- f) Baking is required if the humidity indicator inside the bag indicates  $10\%$  RH or more