

Comchips

KX6127 Module Data sheet

KX6127

Module Data sheet

Website: www.comchips.com

Customer Approval

Company _____

Title _____

Signature _____

Date _____

FTY _____

Version Update Record

Version	Date	Revision Content	Editorialstaff
V1.0	2021/10/23	The first version	

approval

CONTENTS



1 Overview	5
1.1 Introduction.....	5
1.2 Features.....	6
1.3 Block Diagram.....	7
1.4 General Specification	7
1.5 DC Characteristics	8
2 RF Specifications	9
3 Pin Assignments.....	10
3.1 Pin Outline	10
3.2 Pin Definition	10
4 Dimensions	11
4.1 Module Picture	11
4.2 Module Physical Dimensions	11
5 Reference Design	12
6 The Key Material List	12
7 Recommended Reflow Profile	13
8 Package Information	13
8.1 Reel	13
8.2 Carrier Tape Detail	14
8.3 Packaging Detail.....	14
8.4 Moisture sensitivity	15

1 Overview

1.1 Introduction

KX6127 is a highly integrated module, it puts a wireless LAN MAC, a 1T1R capability of the wireless LAN baseband, and wireless LAN RF set together. This module provides a complete solution for integrated WLAN devices with high throughput performance. Supports all IEEE 802.11b and 802.11g data rates, providing support for traditional data rates, powerful interference detection and suppression offers to prevent interference from Bluetooth, cordless phones and microwave ovens. It has synchronous and asynchronous control loop between antennas, antenna diversity function and adaptive transmission power control function to obtain better performance of the analog part of the transceiver.

1.2 Features

- CMOS MAC, Baseband PHY, and RF in a single chip for IEEE 802.11b/g/n compatible WLAN
- Support 20MHz, bandwidth in 2.4GHz band
- IEEE 802.11 b/g/n/ compliant max 65 Mbps
- GSPI interface for configurable endian for WLAN
- Frame aggregation for increased MAC efficiency (A-MSDU, A-MPDU)
- Low latency immediate High-Throughput Block Acknowledgement (HT-BA)
- Channel management and co-existence
- One Transmit and one Receive path (1T1R)
- DSSS with DBPSK and DQPSK, CCK modulation with long and short preamble
- OFDM with BPSK, QPSK, 16QAM, and 64QAM modulation. Convolutional Coding Rate: 1/2, 2/3, 3/4, and 5/6

1.3 Block Diagram

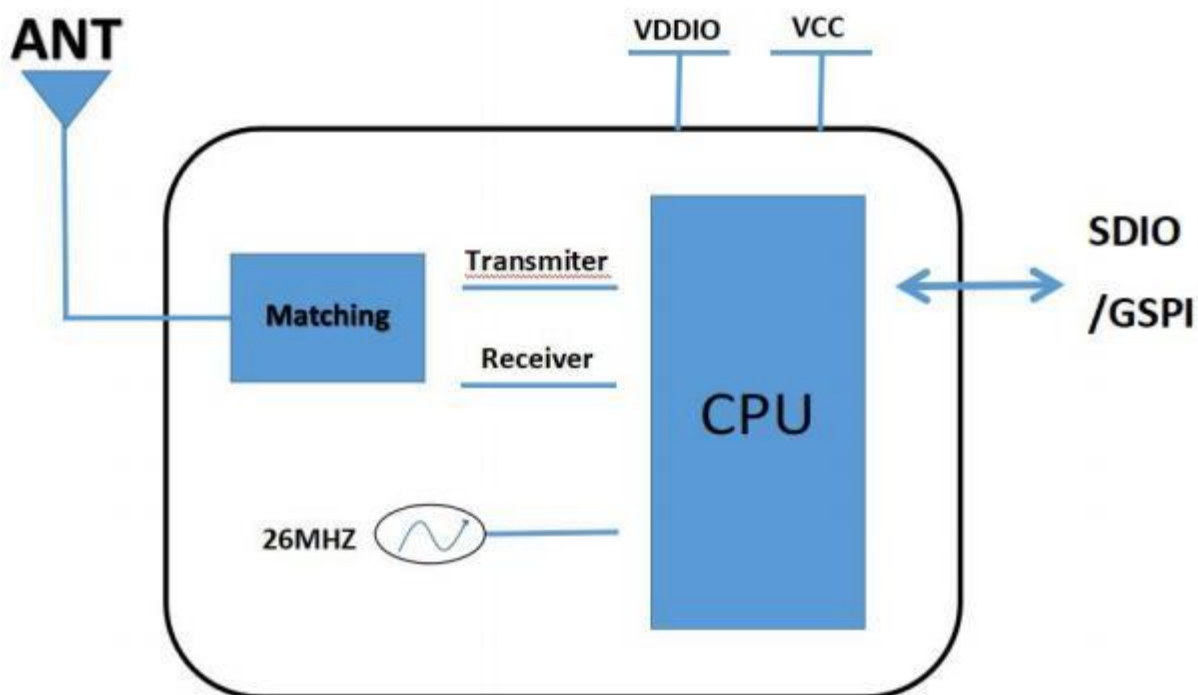

1.4 General Specification

Model Name	KX6127
Product Description	Support WIFI:IEEE802.11 11b/g/n
Dimension	L x W x H: 12 x 12 x 1.6mm
Wi-Fi Interface	Support:GSPI/SDIO
BT interface	N/C
Operating temperature	0 to +70° C
Storage temperature	-55°C to 125°C
RoHS	All hardware components are fully compliant with EU RoHS directive

1.5 DC Characteristics



(1) Power Supply Characteristics

Symbol	Parameter	Minimum	Typical	Maximum	Units
VDD33	3.3V Power Supply Voltage	3.0	3.3	3.6	V
IDD33	3.3V Rating Current	/	/	600	mA

(2) Digital IO Pin DC Characteristics

Symbol	Parameter	Minimum	Typical	Maximum	Units	
VDDIO(pin#22)	3.3V I/O Power Voltage	V _{IH}	2.0	3.3	3.6	V
		V _{IL}	--	0	0.9	V
		V _{OH}	2.97	--	3.3	V
		V _{OL}	0	--	0.33	V
	1.8V I/O Power Voltage	V _{IH}	1.7	1.8	2.0	V
		V _{IL}	--	0	0.8	V
		V _{OH}	1.62	--	1.8	V
		V _{OL}	0	--	0.18	V
CS(PIN#12)	Chip select	V _{IH}	2.0	3.3	3.6	V
		V _{IL}	--	0	0.9	V
WL HOST WAKE (PIN#13)	WLAN wake-up HOST	V _{OH}	2.97	--	3.3	V
		V _{OL}	0	--	0.33	V

2 RF Specifications



Features	Description		
WLAN Standard	WLAN 11b/g/n		
Frequency Range	2.400 ~ 2.483 GHz		
Operating Channel	11: (Ch. 1-11) – United States 13: (Ch. 1-13) – Europe 14: (Ch. 1-14) – Japan		
Network Architecture	Ad-hoc mode (Peer-to-Peer) Infrastructure mode Scatter Net		
Security	WPA,WPA-PSK,WPA2,WPA2-PSK,WEP64bit&128bit,IEEE802. 11x, IEEE 802. 11i		
OS Support	Windows XP/Win7/Linux/Android		
2.4G Transmitter Specifications			
TX Rate	TX Power	TX Power Tolerance	EVM
802.1 1b @ 11 Mbps	17dBm	±2dBm	≤-13dB
802. 11g@54Mbps	14dBm	±2dBm	≤-25dB
802.11n@HT20_MC S7	13dBm	±2dBm	≤-28dB
2.4G Receiver Specifications			
RX Rate	Min Input Level(Typ)	Max Input Level(Typ)	PER
802.1 1b @ 11 Mbps	-85dBm	-85dBm	8%
802. 11g@54Mbps	-68dBm	-68dBm	10%
802.11n@HT20_MC S7	-66dBm	-66dBm	10%

3 Pin Assignments

3.1 Pin Outline

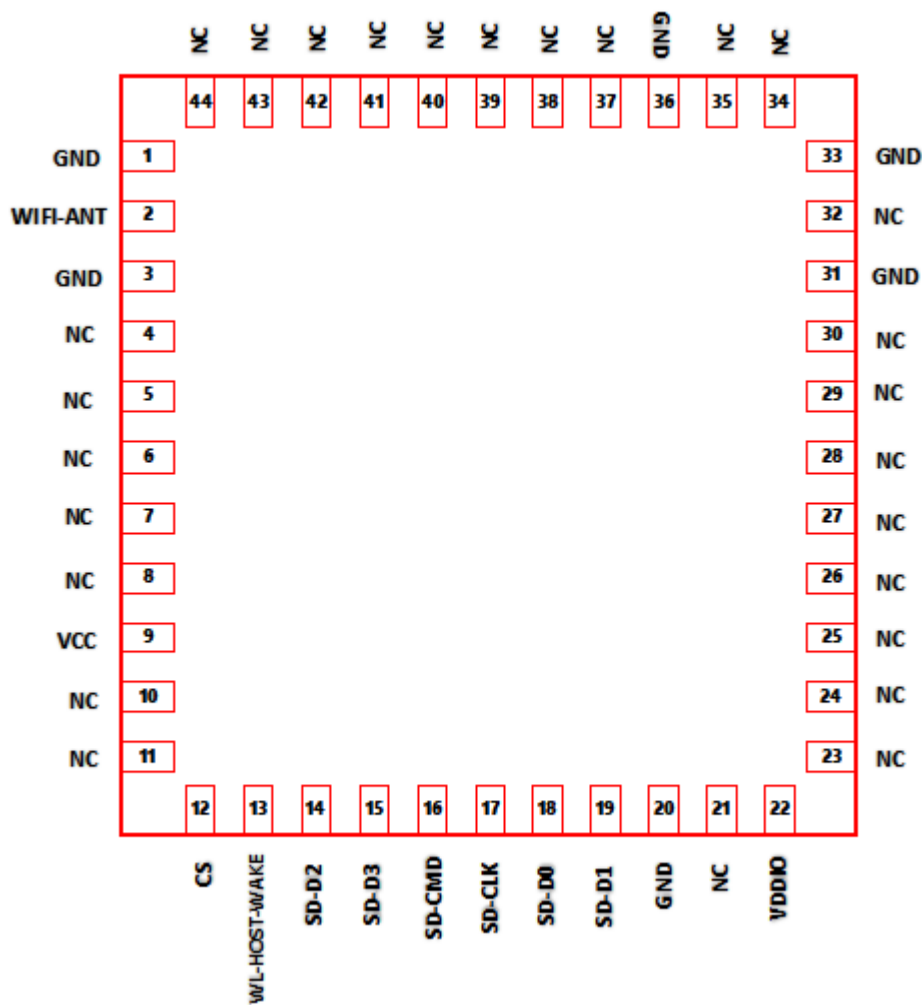

3.2 Pin Definition



Pin	Function	Description
1	GND	GND
2	WIFI_ANT	RF RX&TX Signal
3	GND	GND
4-8	NC	NC
9	VDD33	Power supply for system (3.3V±0.3V)
10-11	NC	NC
12	CS	Chip select, Activity high; Internal pull high to 3.3V at 100K Ω
13	WL_HOST_WAKE	For WLAN wake-up HOST, Internal pull high to 3.3V at 100KΩ
14	SD_D2	SDIO Data Line 2
15	SD_D3	SDIO Data Line 3
16	SD_CMD	SDIO Command Input
17	SD_CLK	SDIO Clock Input
18	SD_D0	SDIO Data Line 0
19	SD_D1	SDIO Data Line 1
20	GND	GND
21	NC	NC
22	VDDIO	VDD for SDIO Pin, the power supply is same as the signal level of SDIO bus (3.3V ~ 1.8V)
23-30	NC	NC
31	GND	GND
32	NC	NC
33	GND	GND
34-35	NC	NC
36	GND	GND
37-44	NC	NC

4 Dimensions

4.1 Module Picture

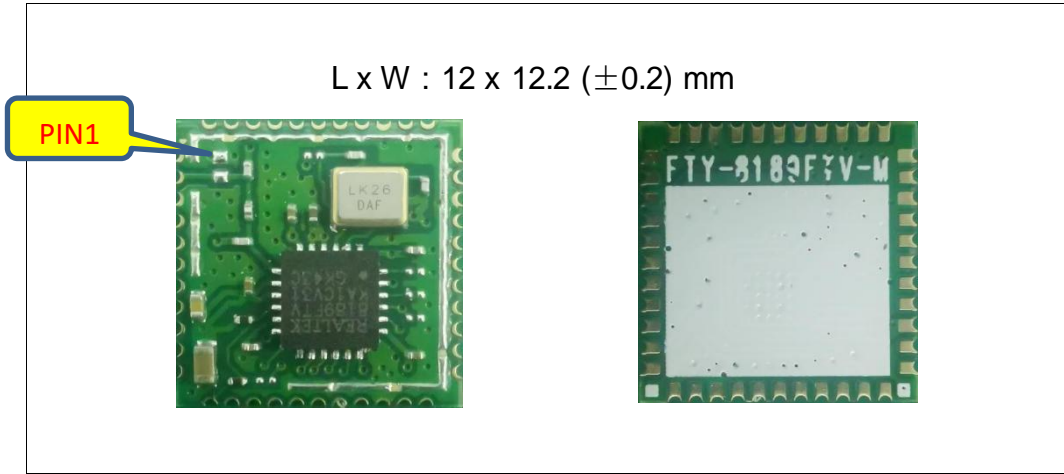

4.2 Module Physical Dimensions

(Unit: mm)

< TOP VIEW >

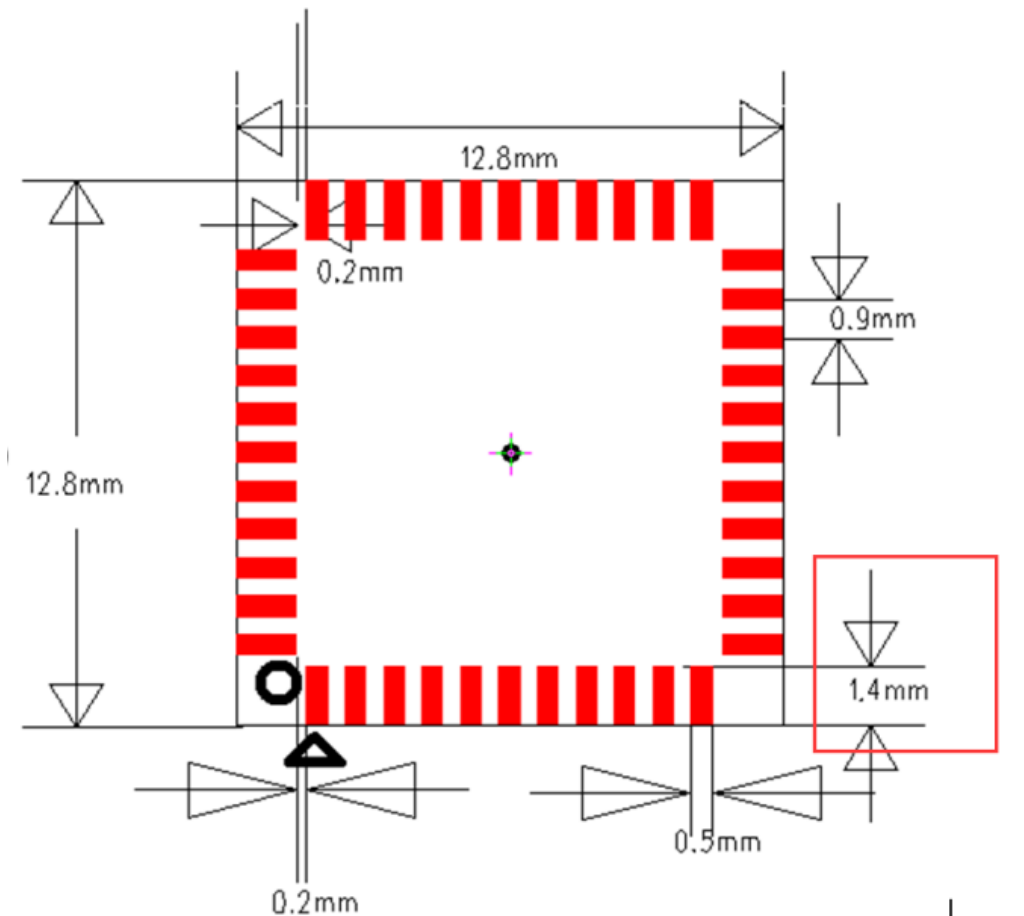

5 Reference Design

5.1 Circuit reference pictures

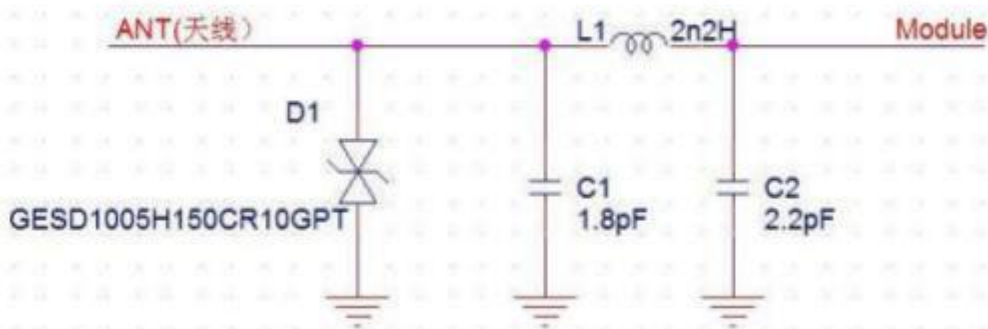

5.2 SDIO interface Circuit reference pictures

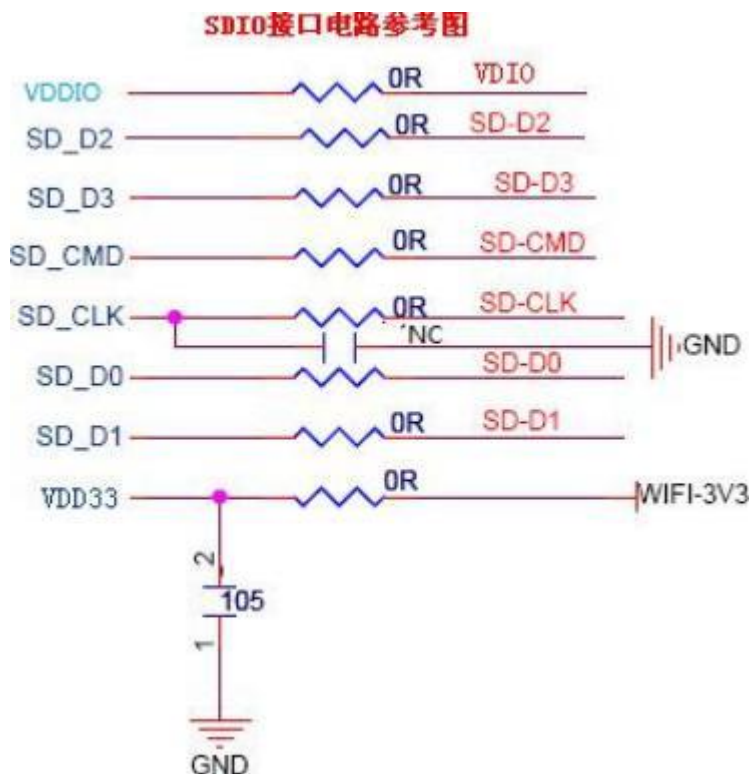

5.3 CS WAKE Reference circuits.

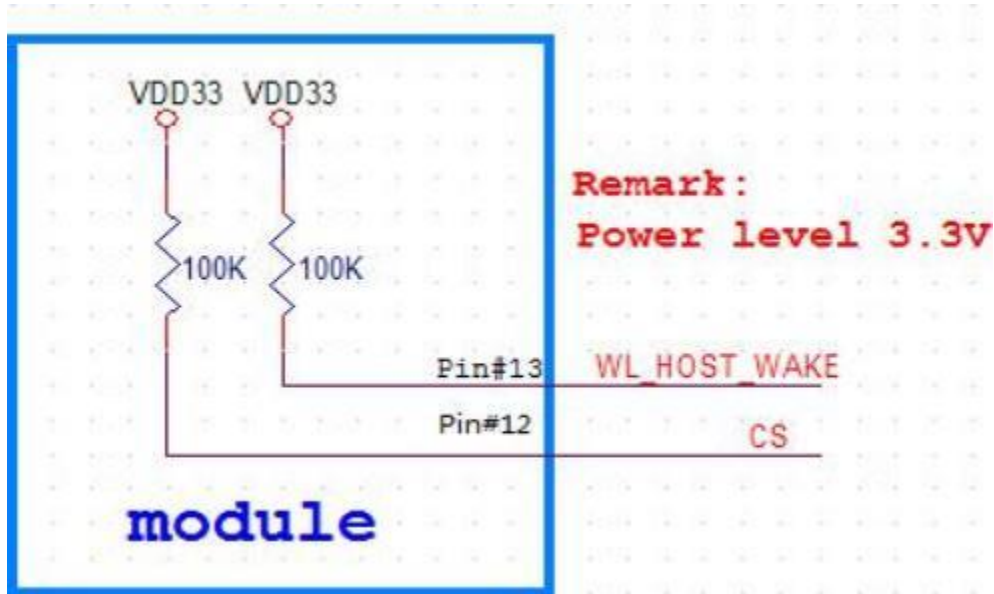

6 The Key Material List

No.	Parts	Specification	Manufacturer	Note
1	Chipset	RL8189FTV-VQ1	Realtek Semiconductor Corp	
2	PCB	8189FTV-M-V1.0	Shenzhen xiangyu circuit co., LTD	
3	PCB	8189FTV-M-V1.0	Shenzhen Kexiang Precision Circuit Technology Co., LTD	
4	Crystal oscillator	3225 40MHZ 12PF +/- 10PPM -20+85°C 川晶	hefei jing wei Electronics Co. Ltd	
5	Crystal oscillator	3225 40MHZ 12PF +/- 10PPM -20+85°C 川晶	ZhejiangLanjingxin Microelectronics Co., LTD	

7 Recommended Reflow Profile

Referred to IPC/JEDEC standard.

Peak Temperature : <math>< 250^{\circ}\text{C}</math>

Number of Times : ≤ 2 times

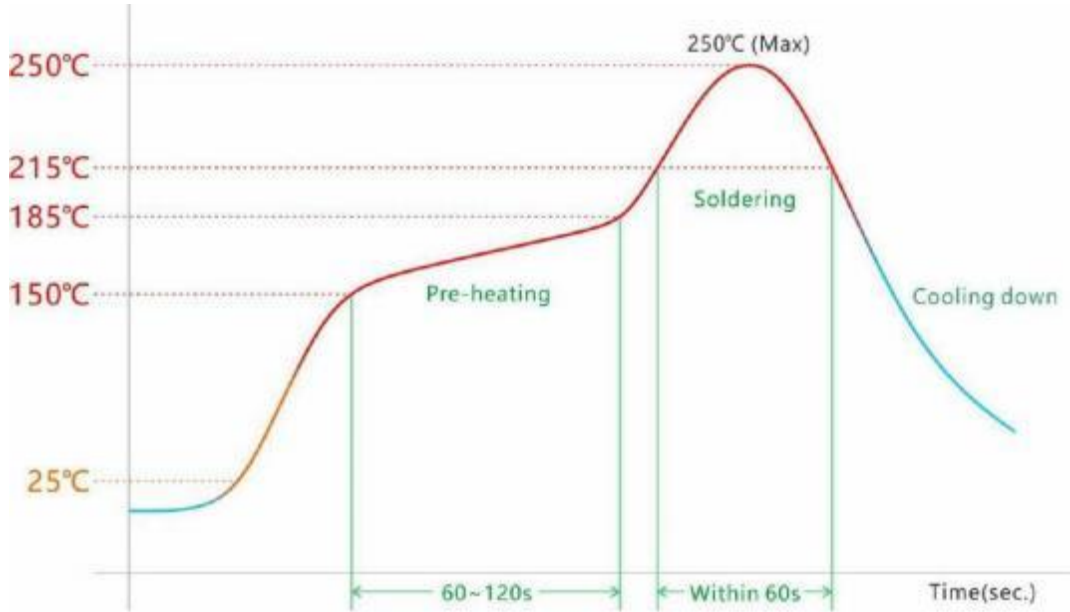

Package Information

8.1 Reel

A roll of 2000pcs

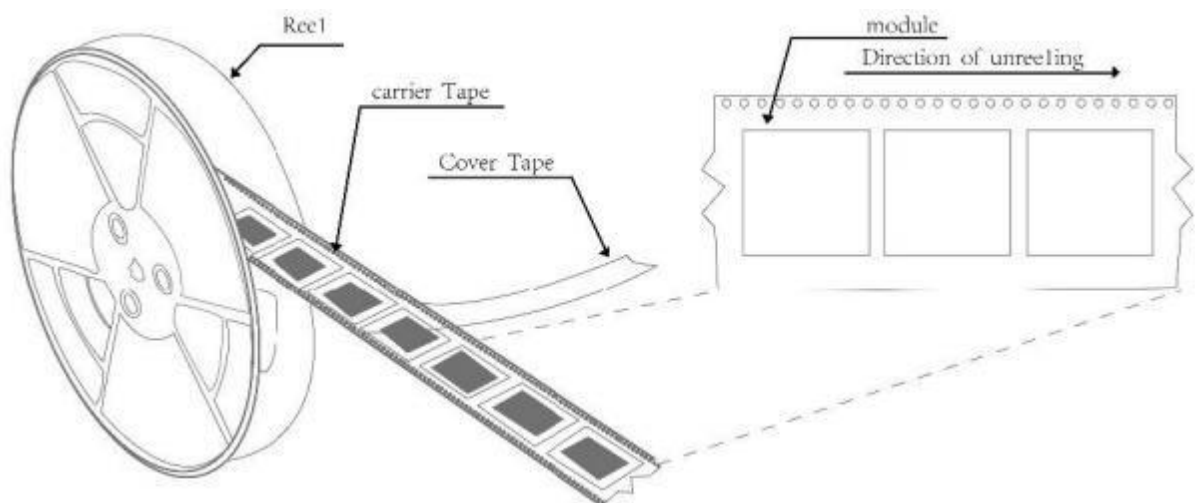

8.2 Carrier Tape Detail

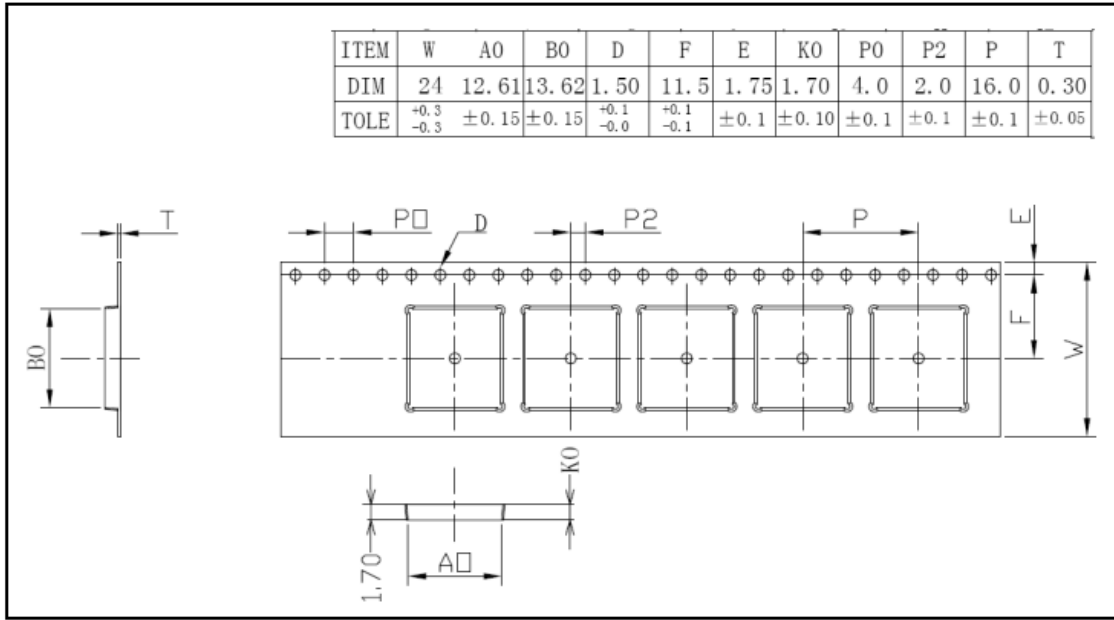

8.3 Packaging Detail

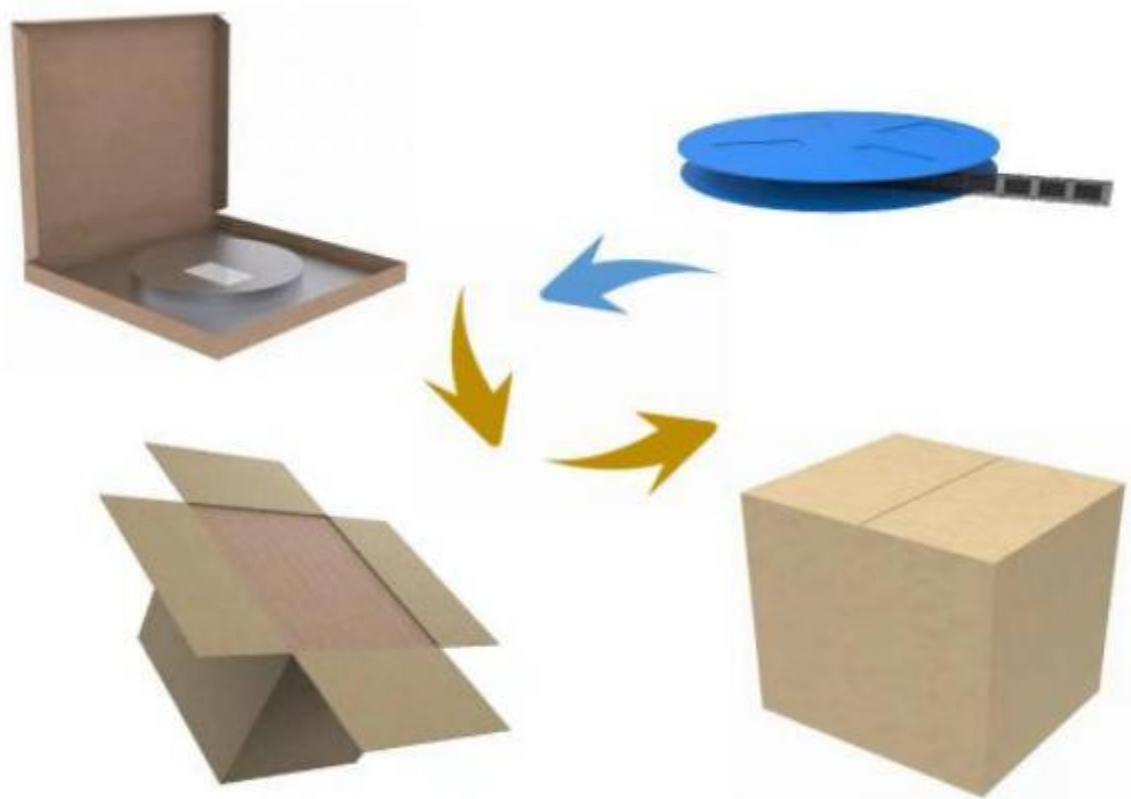

8.4 Moisture sensitivity

The Modules is a Moisture Sensitive Device level 3, in according with standard IPC/JEDEC J-STD-020, take care all the relatives requirements for using this kind of components.

Moreover, the customer has to take care of the following conditions:

- a) Calculated shelf life in sealed bag: 12 months at <math><40^{\circ}\text{C}</math> and <math><90\%</math> relative humidity (RH).
- b) Environmental condition during the production: - c) The maximum time between the opening of the sealed bag and the reflow process must be 168 hours if condition
- b) "IPC/JEDEC J-STD-033A paragraph 5.2" is respected
- e) Baking is required if conditions b) or c) are not respected
- f) Baking is required if the humidity indicator inside the bag indicates 10% RH or more