



KX6336 Module Data sheet

KX6336

Module Data sheet

Website: www.comchips.com

Customer Approval

Company

Title

Signature

Date

FTY

Version Update Record

Version	Date	Revision Content	Editorialstaff	approval
V1.0	2022/7/4	The first version		

CONTENTS

1 Overview	5
1.1 Introduction	5
1.2 Features	5
1.3 Block Diagram	6
1.4 General Specification.....	6
1.5 DC Characteristics	7
2 RF Specifications	8
2.1 2.4GHz RF Specification	8
2.2 5GHz RF Specification	9
2.3 5GHz(20MHz) Channel table.....	10
2.4 Bluetooth Section:.....	11
3 Pin Assignments	12
3.1 Pin Outline	12
3.2 Pin Definition.....	13
4 Dimensions	15
4.1 Module Picture.....	15
4.2 Module Physical Dimensions	15
5 Reference Design	16
6 The Key Material List	17
7 Recommended Reflow Profile	18
8 Package Information	18
8.1 Reel	18
8.2 Carrier Tape Detail.....	19
8.3 Packaging Detail.....	10
8.4 Moisture sensitivity	20

1 Overview

1.1 Introduction

The KX6336 is a highly integrated single-chip that support 802.11ac solutions with Multi-user MIMO (Multiple-Input, Multiple-Output) with integrated Bluetooth 2.1/3.0/4.1/5.0 controller, SDIO (SDIO 1.1/2.0/3.0) interface, and HS-UART mixed interface. It combines a WLAN MAC, a 2T2R capable WLAN baseband, and RF in a single chip. The KX6336 provides a complete solution for a high-performance integrated wireless and Bluetooth device.

1.2 Features

- CMOS MAC, Baseband PHY and RF in a single chip for IEEE 802.11a/b/g/n/ac compatible WLAN
- Support 802.11ac 2x2, Wave-2 compliant with MU-MIMO
- Support 20/40MHz at 2.4GHz
- Supports 20/40/80MHz at 5GHz
- Support WLAN-Bluetooth coexistence
- Support low power Bluetooth
- Bluetooth 5.0 Dual Mode Support: Both LE and BR/BDR are supported

1.3 Block Diagram

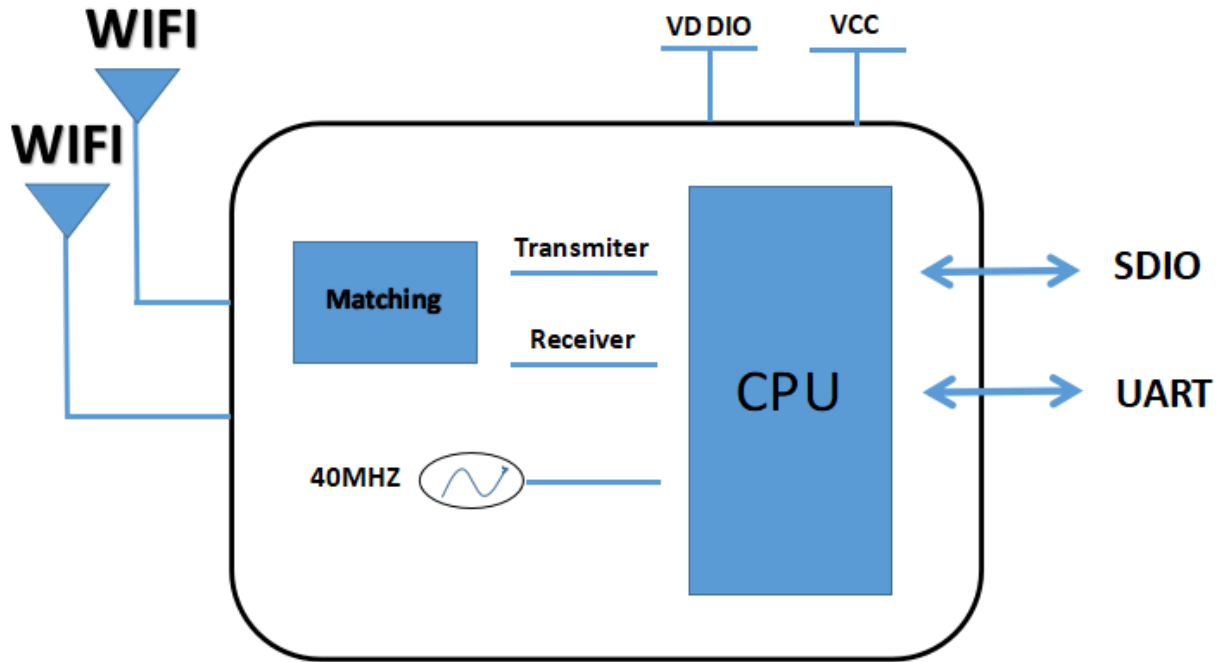

1.4 General Specification

Model Name	KX6336
Product Description	WiFi5 and Bluetooth PCIE Module
Dimension	L x W x H: 15x 13x2.3 (± 0.3) mm
Wi-Fi Interface	Support SDIO 3.0
BT interface	Support UART
Operating temperature	0 to +70° C
Storage temperature	-55°C to 125°C
RoHS	All hardware components are fully compliant with EU RoHS directive

1.5 DC Characteristics

Power Supply Characteristics

symbol	Parameter	Minimum	Typical	Maximum	Units
VCC	3.3V supply voltage	3.1	3.3	3.5	V
VCC	3.3V rating current	--	--	1500	mA

2 RF Specifications

2.1 2.4GHz RF Specification

Features	Description		
WLAN Standard	IEEE802.11b/g/n		
Frequency Range	2.4~2.4835GHz (2.4GHz ISM Band)		
Modulation Method	DSSS,DBPSK, DQPSK, CCK and OFDM (BPSK, QPSK, 16QAM,64QAM)		
Number of Channel	2.4GHz: 11: (Ch. 1-11) – United States 13: (Ch. 1-13) – Europe 14: (Ch. 1-14) – Japan		
2.4G Transmitter Specifications			
TX Rate	TX Power	TX Power Tolerance	EVM
802.11b @ 11 Mbps	17dBm	±2dBm	≤-13dB
802.11g@54Mbps	14dBm	±2dBm	≤-25dB
802.11n@BW20_MC S7	13dBm	±2dBm	≤-28dB
802.11n@BW40_MC S7	13dBm	±2dBm	≤-28dB
Frequency Error: ±12PPM			
2.4G Receiver Specifications			
RX Rate	Standard Value		PER
802.11b @ 11Mbps	≤-85dBm		8%
802.11g@54Mbps	≤-70dBm		10%
802.11n@BW20_MC S7	≤-65dBm		10%
802.11n@BW40_MC S7	≤-65dBm		10%

2.2 5GHz RF Specification

Features	Description		
WLAN Standard	IEEE802.11a/n/ac		
Frequency Range	4.9GHz ~ 6.0GHz (5GHz ISM Band)		
Modulation Method	OFDM(BPSK, QPSK, 16QAM,64QAM and 256-QAM)		
5G Transmitter Specifications			
TX Rate	TX Power	TX Power Tolerance	EVM
802.11a @ 54Mbps	13dBm	±2dBm	≤-25dB
802.11n@BW20_MC S7	12dBm	±2dBm	≤-28dB
802.11n@BW40_MC S7	12dBm	±2dBm	≤-28dB
802.11ac@BW80_M CS9	10dBm	±2dBm	≤-32dB
5G Receiver Specifications			
RX Rate	Standard Value		PER
802.11a@54Mbps	≤-70dBm		<10%
802.11n@BW20_MC S7	≤-65dBm		< 10%
802.11n@BW40_MC S7	≤-60dBm		< 10%
802.11ac@BW80_M CS9	≤-57dBm		< 10%

2.3 5GHz(20MHz) Channel table

Band (GHz)	Operating Channel Numbers	Channel centr frequencies(MHz)
5.15GHz~5.25GHz	36	5180
	40	5200
	44	5220
	48	5240
5.25GHz~5.35GHz	52	5260
	56	5280
	60	5300
	64	5320
5.5GHz~5.7GHz	100	5500
	104	5520
	108	5540
	112	5560
	116	5580
	120	5600
	124	5620
	128	5640
	132	5660
	136	5680
5.725GHz~5.825GHz	140	5700
	149	5745
	153	5765
	157	5785
	161	5805
	165	5825

2.4 Bluetooth Section:

Feature	Description		
General Specification			
Bluetooth Standard	Bluetooth V5.0 of 1, 2 and 3 Mbps.		
Host Interface	UART		
Frequency Band	2402 MHz ~ 2480 MHz		
Number of Channels	79 channels		
Modulation	FHSS, GFSK, DPSK, DQPSK		
RF Specification			
Power (BDR: GFSK/1Mbps)	0dBm	---	10dBm
Power(EDF: $\pi/4$ -DQPSK/2Mbps)	0dBm	---	10dBm
Power (BLE: GFSK/1Mbps)	0dBm	---	10dBm
Sensitivity @ BER=0.1% for (BDR: GFSK/1Mbps)		-85 dBm	
Sensitivity @ BER=0.1% for(EDF: $\pi/4$ -DQPSK/2Mbps)		-85 dBm	
Sensitivity @ BER=0.1% for (BLE: GFSK/1Mbps)		-85 dBm	
Initial Freq Error	BDR: GFSK/1Mbps: ± 75 KHZ		
	EDF: $\pi/4$ -DQPSK/2Mbps : ± 75 KHZ		
	BLE: GFSK/1Mbps : ± 75 KHZ		

3. Pin Assignments

3.1 Pin Outline

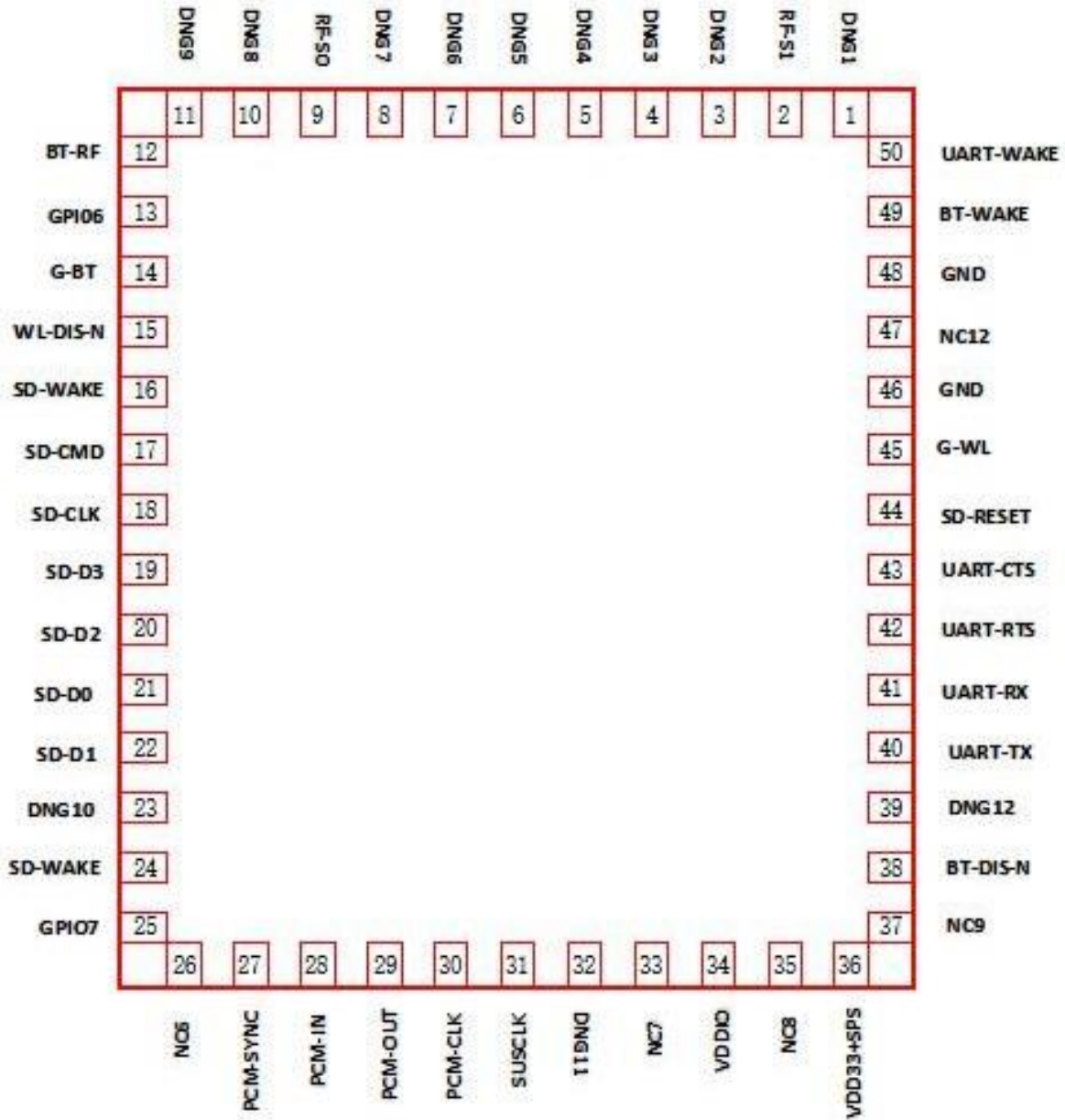

3.2 Pin Definition

NO.	Name	Type	Description
1	GND	—	Ground connections
2	RF_S1	I/O	ANT1
3	GND	—	Ground connections
4	GND	—	Ground connections
5	GND	—	Ground connections
6	GND	—	Ground connections
7	GND	—	Ground connections
8	GND	—	Ground connections
9	RT_S0	I/O	ANT0
10	GND	—	Ground connections
11	GND	—	Ground connections
12	NC	—	No connect
13	GPIO6	—	General Purpose Input/ Output Pin
14	G_BT	—	General Purpose Input/ Output Pin
15	WL_DIS_N	I	RF on-off
16	SD_WAKE	O	WLAN to wake-up HOST
17	SD_CMD	I/O	SDIO command line
18	SD_CLK	I/O	SDIO CLK
19	SD_D3	I/O	SDIO Data Line 3
20	SD_D2	I/O	SDIO Data Line 2
21	SD_D0	I/O	SDIO Data Line 0
22	SD_D1	I/O	SDIO Data Line 1
23	GND	—	Ground connections
24	SD_WAKE	O	WLAN to wake-up HOST
25	GPIO7	—	General Purpose Input/ Output Pin
26	NC	—	No connect
27	PCM_SYNC	I/O	PCM sync signal

28	PCM_IN	I	PCM DATA INPUT
29	PCM_OUT	I	PCM DATA OUTPUT
30	PCM_CLK	I/O	PCM CLK
31	SUSCLK	—	External Low Power Clock input(32.768KHz)
32	GND	—	Ground connections
33	NC	—	No connect
34	VDDIO	P	I/O Voltage supply input 1.8V or 3.3V
35	NC	—	No connect
36	VD33_SPS	P	3.3V
37	NC	—	No connect
38	BT_DIS_N	—	Enable pin for Bluetooth device ON: pull high ; OFF: pull low
39	GND	—	Ground connections
40	UART_TX	O	High-Speed UART Data Out
41	UART_RX	I	High-Speed UART Data In
42	UART_RTS	O	High-Speed UART RTS
43	UART_CTS	I	High-Speed UART CTS
44	SD_RESET	—	SDIO BUS REST
45	G_WL	—	General Purpose Input/ Output Pin
46	GND	—	Ground connections
47	NC	—	No connect
48	GND	—	Ground connections
49	BT_WAKE	—	Host wake-up Bluetooth device
50	UART_WAKE	O	Bluetooth device to wake-Host

4.Dimensions

4.1 Module Picture

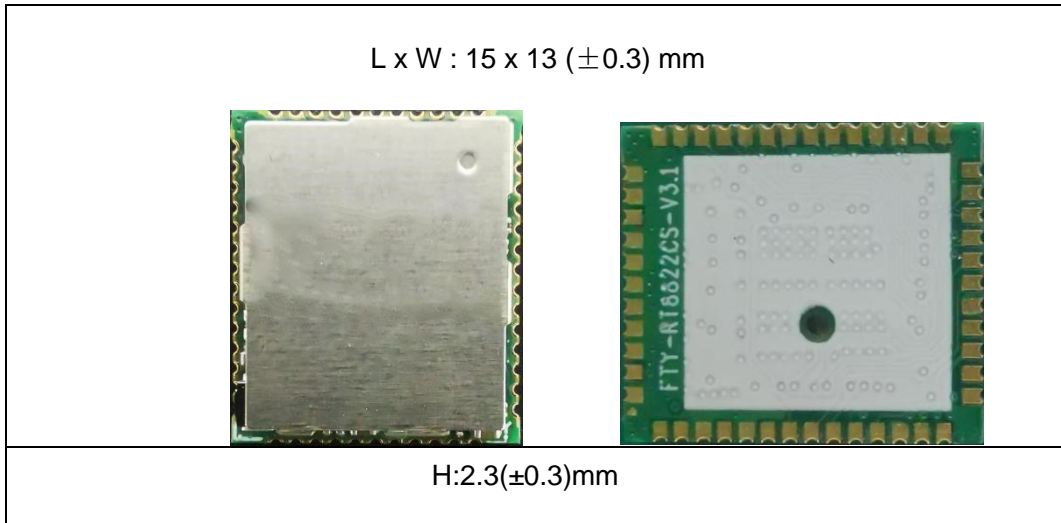

4.2 Module Physical Dimensions

(Unit: mm)

< TOP VIEW >

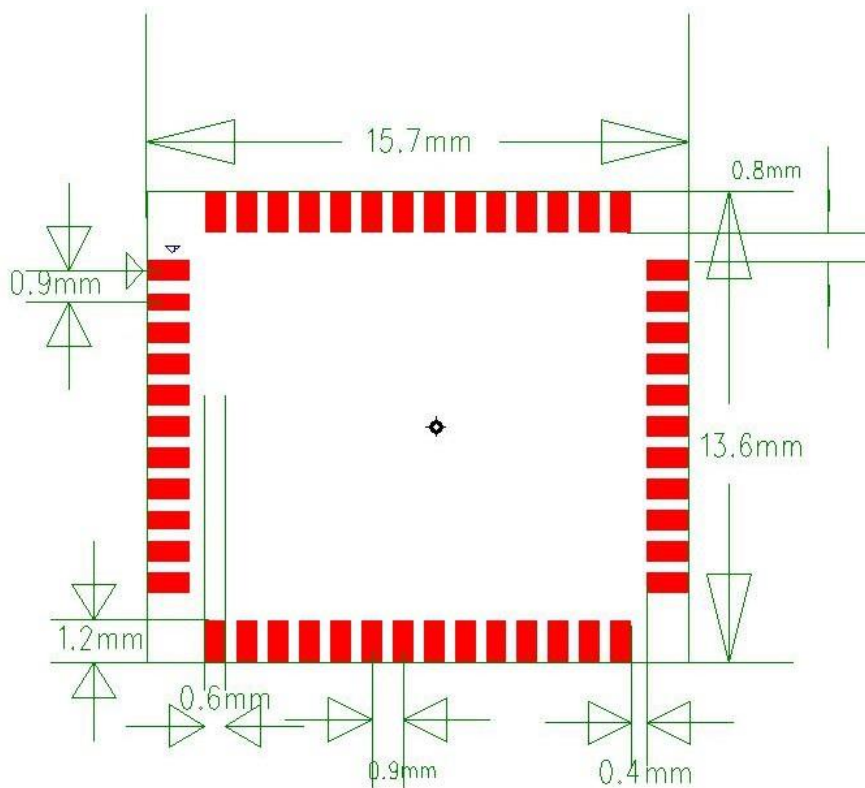

5.Reference Design

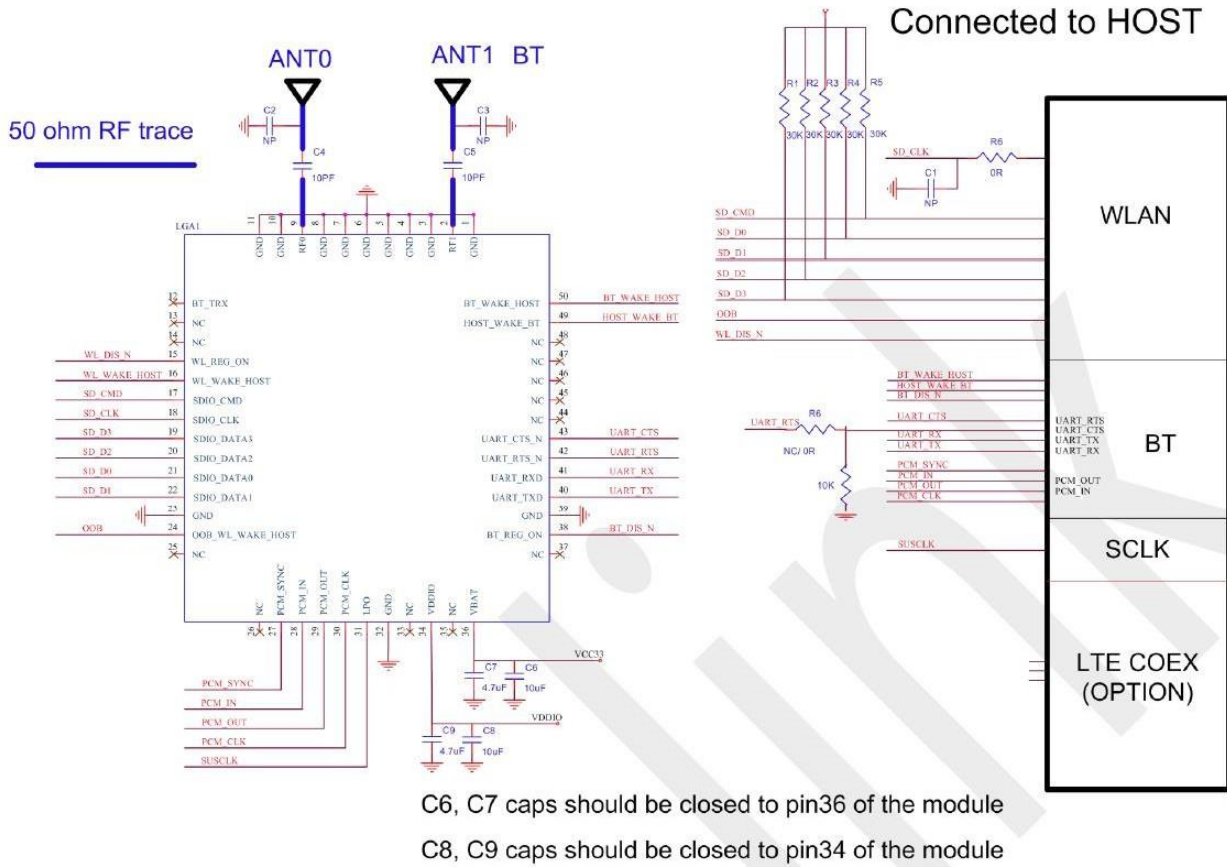

Note:

- 1.ANT_A, ANT_B are all support 2.4G/5G function,ANT_B is support Bluetooth also;
- 2.The module requires independent power supply, supply capacity $\geq 1000\text{mA}$ and ripple less than 150mV;
- 3.Do not share power with amplifier, camera, etc.

6.The Key Material List

No.	Parts	Specification	Manufacturer	Note
1	Chipset	RTL8822CS-VE-CG	Realtek Semiconductor Corp	
2	PCB	FTY_RT8822CS-V3.1	Shenzhen xiangyu circuit co., LTD	
3	PCB	FTY_RT8822CS-V3.1	Shenzhen Kexiang Precision Circuit Technology Co., LTD	
4	Crystal oscillator	3225 40MHZ 12PF +/- 10PPM -20+85℃	hefei jing wei Electronics Co. Ltd	
5	Crystal oscillator	3225 40MHZ 12PF +/- 10PPM -20+85℃	ZhejiangLanjingxin Microelectronics Co., LTD	
6	duplexor	双工器 1.6×0.8mm 6P 2.4GHz/5GHz RFDIP160806BLM6T25 华新科	Shenzhen gangxinda Electronic Technology Co., LTD	
7	duplexor	双工器 1.6×0.8mm 6P 2.4GHz/5GHz DPX1608R24554K85 (HEK)	Dongguan Hekang Electronics Co., LTD	

7 Recommended Reflow Profile

Referred to IPC/JEDEC standard.

Peak Temperature : <math>< 250^{\circ}\text{C}</math>

Number of Times : ≤ 2 times

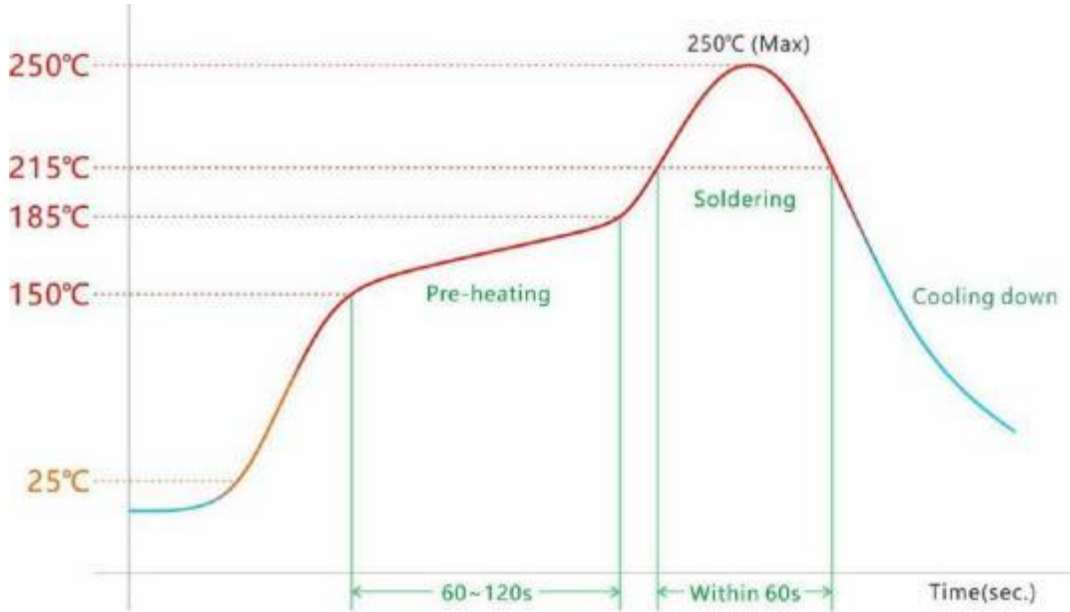

8 Package Information

8.1 Reel

A roll of 2000pcs

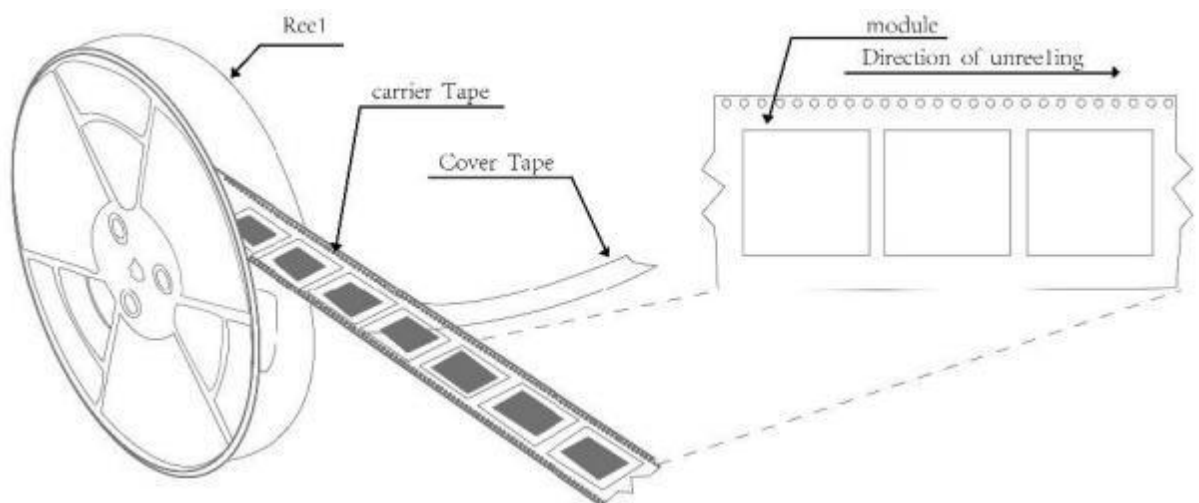

8.2 Carrier Tape Detail

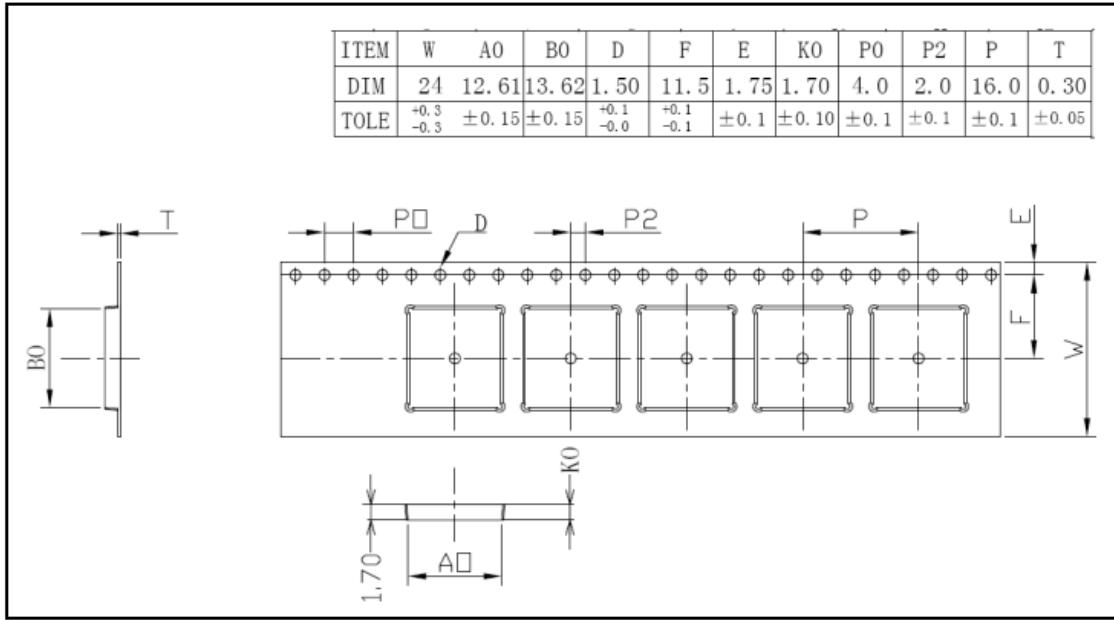

8.3 Packaging Detail

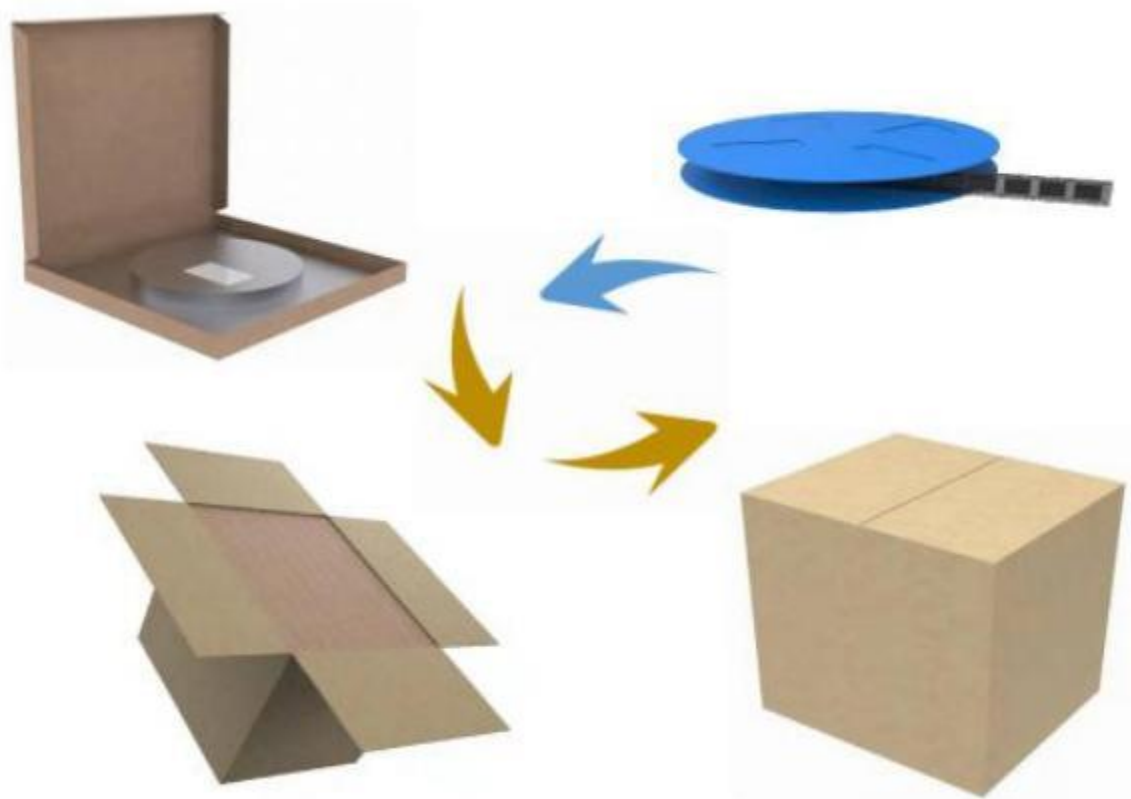

8.4 Moisture sensitivity

The Modules is a Moisture Sensitive Device level 3, in according with standard IPC/JEDEC J-STD-020, take care all the relatives requirements for using this kind of components.

Moreover, the customer has to take care of the following conditions:

- a) Calculated shelf life in sealed bag: 12 months at 40°C and 90% relative humidity (RH).
- b) Environmental condition during the production: 30°C / 60% RH according to IPC/JEDEC J-STD-033A paragraph 5.
- c) The maximum time between the opening of the sealed bag and the reflow process must be 168 hours if condition
- b) "IPC/JEDEC J-STD-033A paragraph 5.2" is respected
- e) Baking is required if conditions b) or c) are not respected
- f) Baking is required if the humidity indicator inside the bag indicates 10% RH or more