



KX6576 Module Data sheet

KX6576

Module Data sheet

Website: www.comchips.com

Customer Approval

Company

Title

Signature

Date

FTY

Version Update Record

Version	Date	Revision Content	Editorialstaff	approval
V1.0	2022/5/18	The first version		

CONTENTS

1 Overview	5
1.1 Introduction	5
1.2 Features	6
1.3 Block Diagram	7
1.4 General Specification.....	7
1.5 DC Characteristics	8
2 RF Specifications	9
2.1 2.4GHz RF Specification	9
2.2 5GHz RF Specification	10
2.3 Bluetooth Section:.....	11
3 Pin Assignments	12
3.1 Pin Outline	12
3.2 Pin Definition.....	13
4 Dimensions	14
4.1 Module Picture.....	14
4.2 Module Physical Dimensions	14
5 Reference Design	15
5.1 WIFI RF Circuit reference pictures4.2	15
5.2 USB interface electrical characteristics	15
6 The Key Material List	16
7 Recommended Reflow Profile	16
8 Package Information	17
8.1 Reel	17
8.2 Carrier Tape Detail	17
8.3 Packaging Detail.....	18
8.4 Moisture sensitivity	18

1 Overview

1.1 Introduction

The KX6576 is a highly integrated single-chip that support 2-stream 802.11ax solutions with Multi-user MIMO (Multiple-Input, Multiple-Output) with Wireless LAN (WLAN) USB network interface controller with integrated Bluetooth 5 USB interface controller. It combines a WLAN MAC, a 2T2R capable WLAN baseband, and RF in a single chip. The RTL8852BU provides a complete solution for a high-performance integrated wireless and Bluetooth device.

The KX6576 baseband implements Multi-user Multiple Input, Multiple Output (MU-MIMO) Orthogonal Frequency Division Multiplexing (OFDM) with two transmit and two receive paths (2T2R). Features include two spatial stream transmissions, short Guard Interval (GI), spatial spreading, and support for variant channel bandwidth. Moreover, KX6576 provides one spatial stream space-time block code (STBC), Transmit Beamforming (TxBF) and Low Density Parity Check (LDPC) to extend the range of transmission. At the receiver, extended range and good minimum sensitivity is achieved by having receiver diversity up to 2 antennas. As the recipient, the KX6576 also supports explicit sounding packet feedback that helps senders with beamforming capability.

1.2 Features

- CMOS MAC, Baseband PHY and RF in a single chip for IEEE 802.11a/b/g/n/ac/ax compatible WLAN
- Support Bluetooth 5 system (BT 5.2 Logo Compliant)
- Complete 802.11n MIMO solution for 2.4GHz and 5Ghz band
- Maximum PHY data rate up to 286.8 Mbps using 20MHz bandwidth, 573.5Mbps using 40MHz bandwidth, and 1201Mbps using 80MHz bandwidth
- Backward compatible with 802.11a/b/g devices while operating at 802.11n data rates
- Backward compatible with 802.11a/n/ac devices while operating at 802.11ax data rates
- Compliance with Windows operating system host-implemented FIPS 140-2 security requirements
- Support 20/40/80MHz 5GHz
- supports WLAN-Bluetooth coexistence
- supports low power Bluetooth
- Support Bluetooth 5 system (BT 5.2 Logo Compliant)
Compatible with Bluetooth v2.1+EDR

1.3 Block Diagram

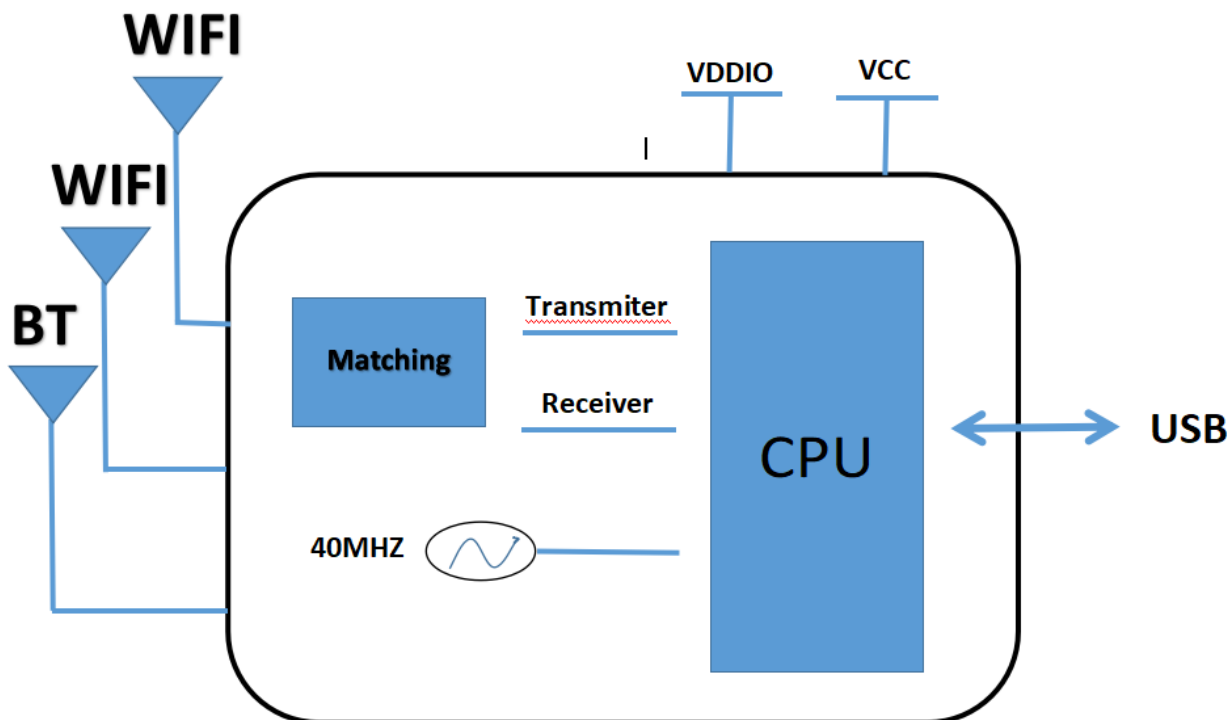

1.4 General Specification

Model Name	KX6576
Product Description	Support WLAN-Bluetooth coexistence
Dimension	L x W x H: 18 x 27 x 1.8(±0.3) mm
Wi-Fi Interface	Support USB
BT interface	Support USB
Operating temperature	0 to +70° C
Storage temperature	-55°C to 125°C
RoHS	All hardware components are fully compliant with EU RoHS directive

1.5 DC Characteristics

Power Supply Characteristics

Symbol	Parameter	Minimum	Typical	Maximum	Units
VDD33	3.3V I/O Supply Voltage	3.1	3.3	3.4	V
VD10	1.05V Core Supply Voltage	0.945	1.05	1.155	V

2 RF Specifications

2.1 2.4GHz RF Specification

Features	Description		
WLAN Standard	IEEE802.11a/b/g/n/ac/ax/e/i/h		
Frequency Range	2.4~2.4835GHz (2.4GHz ISM Band)		
Modulation Method	DSSS, DBPSK, DQPSK, CCK and OFDM (BPSK, QPSK, 16QAM, 64QAM and 256-QAM)		
Number of Channel	2.4GHz: 11: (Ch. 1-11) – United States 13: (Ch. 1-13) – Europe 14: (Ch. 1-14) – Japan		
2.4G Transmitter Specifications			
TX Rate	TX Power	TX Power Tolerance	EVM
802.11b @ 11 Mbps	17dBm	±2dBm	≤ -13dB
802.11g@54Mbps	14dBm	±2dBm	≤ -25dB
802.11n@BW20_MC S7	13dBm	±2dBm	≤ -28dB
802.11n@BW40_MC S7	13dBm	±2dBm	≤ -28dB
2.4G Receiver Specifications			
RX Rate	Min Input Level(Typ)	Max Input Level(Typ)	PER
802.11b@11Mbps	-85dBm	-85dBm	<8%
802.11g@54Mbps	-68dBm	-68dBm	< 10%
802.11n@BW20_MC S7	-66dBm	-66dBm	< 10%
802.11n@BW40_MC S7	-65dBm	-65dBm	< 10%

2.2 5GHz RF Specification

Features	Description		
WLAN Standard	IEEE802.11a/b/g/n/ac/ax/e/i/h		
Frequency Range	4.9GHz ~ 6.0GHz (5GHz ISM Band)		
Modulation Method	DSSS,DBPSK, DQPSK, CCK and OFDM (BPSK, QPSK, 16QAM,64QAM and 256-QAM)		
5G Transmitter Specifications			
TX Rate	TX Power	TX Power Tolerance	EVM
802.11a@ 54Mbps	13dBm	±2dBm	≤-25dB
802.11n@BW20_MCS 7	12dBm	±2dBm	≤-28dB
802.11n@BW40_MC S7	10dBm	±2dBm	≤-30dB
802.11ac@BW80_M CS9	10dBm	±2dBm	≤-32dB
5G Receiver Specifications			
RX Rate	Min Input Level(Typ)	Max Input Level(Typ)	PER
802.11a@54Mbps	-70dBm	-70dBm	<10%
802.11n@BW20_MC S7	-65dBm	-65dBm	< 10%
802.11n@BW40_MC S7	-60dBm	-60dBm	< 10%
802.11ac@BW80_M CS9	-57dBm	-57dBm	< 10%

2.3 Bluetooth Specification

Feature	Description		
General Specification			
Bluetooth Standard	Bluetooth V3.3 of 1, 2 and 3 Mbps		
Host Interface	UART		
Antenna Reference	Small antennas with 0~2 dBi peak gain		
Frequency Band	2.400 GHz ~ 2483.5 GHz		
Number of Channels	79 channels		
Modulation	FHSS, GFSK, DPSK, DQPSK		
RF Specification			
Power (BDR: GFSK/1Mbps)	0dBm	---	10dBm
Power(EDF: $\pi/4$ -DQPSK/2Mbps)	0dBm	---	10dBm
Power (BLE: GFSK/1Mbps)	0dBm	---	10dBm
Sensitivity @ BER=0.1% for (BDR: GFSK/1Mbps)		-85 dBm	
Sensitivity @ BER=0.1% for(EDF: $\pi/4$ -DQPSK/2Mbps)		-85 dBm	
Sensitivity @ BER=0.1% for (BLE: GFSK/1Mbps)		-85 dBm	
Initial Freq Error	BDR: GFSK/1Mbps:±75KHZ		
	EDF: $\pi/4$ -DQPSK/2Mbps :±75KHZ		
	BLE: GFSK/1Mbps :±75KHZ		

3.Pin Assignments

3.1Pin Outline

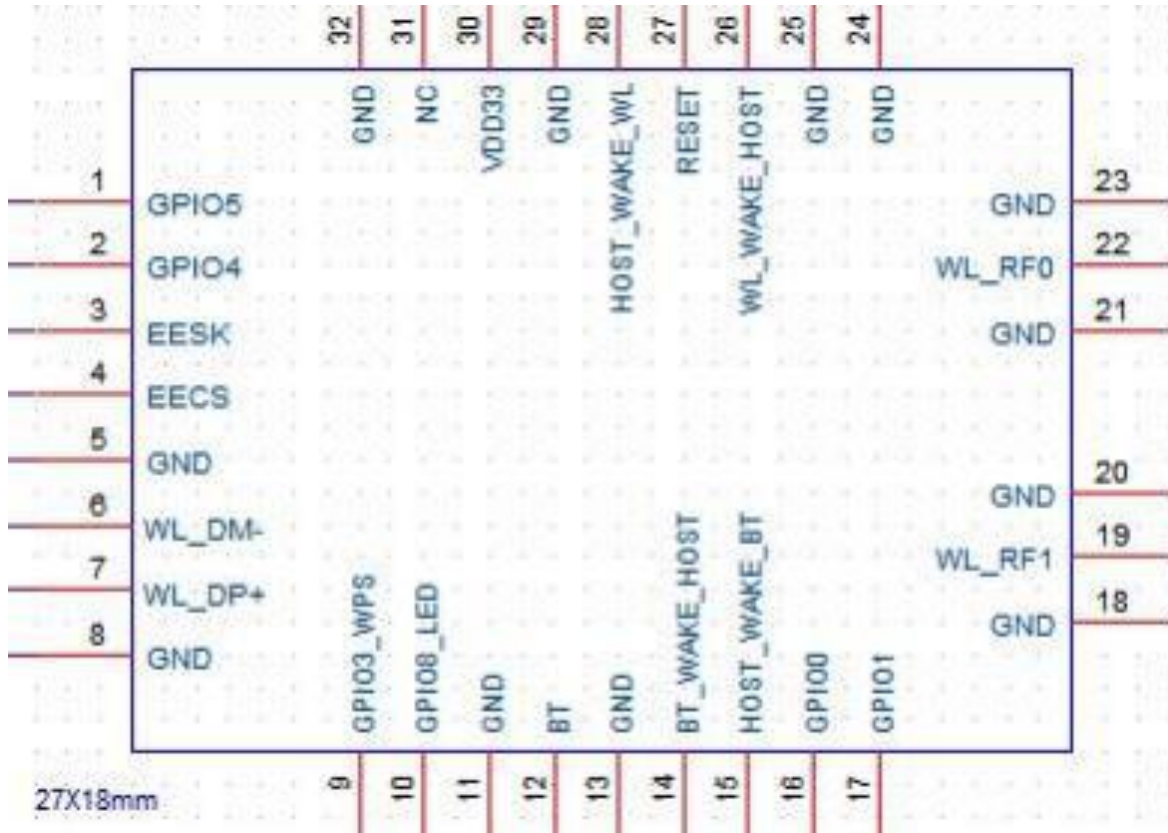

3.2 Pin Definition

NO.	Name	Type	Description
1	GPIO5	I/O	IC GPIO5 (sFlash MISO PIN)
2	GPIO4	I/O	IC GPIO4 (sFlash MOSI PIN)
3	EESK	I/O	External Serial Flash clock (Flash for dongle application)
4	EECS	I/O	External 32K or RTC clock input (Flash CS PIN)
5	GND	—	Ground connections
6	WL DM -	I/O	USB data- (USB2.0)
7	WL DP+	I/O	USB data+ (USB2.0)
8	GND	—	Ground connections
9	GPIO3 WPS	—	IC GPIO3(WLAN WPS)
10	GPIO8 LED	—	IC GPIO8(WLAN LED low active)
11	GND	—	Ground connections
12	BT RF	I/O	BT RF port
13	GND	—	Ground connections
14	BT WAKE HOST	O	BT wake up HOST 3.3V
15	HOST WAKE BT	I	HOST Wake up BT 3.3V
16	GPIO0	—	IC GPIO0
17	GPIO1	—	IC GPIO1
18	GND	—	Ground connections
19	WL RF1	I/O	2.4G/5G Wi-Fi RF port1 / BT Combo (Option)
20	GND	—	Ground connections
21	GND	—	Ground connections
22	WL RF0	I/O	2.4G/5G Wi-Fi RF port0 (Option)
23	GND	—	Ground connections
24	GND	—	Ground connections
25	GND	—	Ground connections
26	WL WAKE HOST	O	WLAN wake up HOST (Shared with IC GPIO6) 3.3V
27	RESET	I	Enable pin for device ON: pull high ; OFF: pull low 3.3V
28	HOST WAKE WL	I	HOST WAKE WLAN (Shared with IC GPIO7) 3.3V
29	GND	—	Ground connections
30	VDD33	P	3.3V Voltage input 3.3V
31	NC	—	No connection (Floating)
32	GND	—	Ground connections

4. Dimensions

4.1 Module Picture

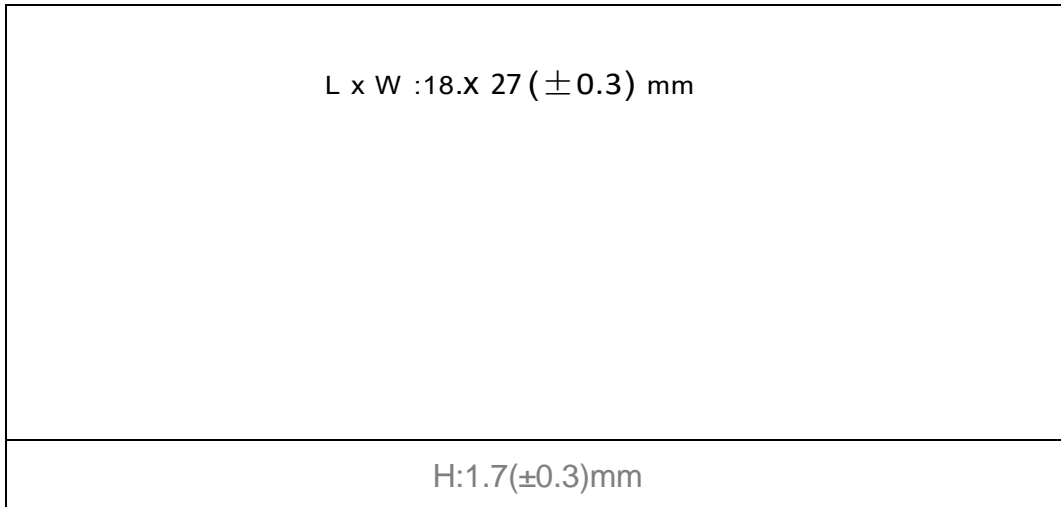

4.2 Module Physical Dimensions

(Unit: mm)

< TOP VIEW >

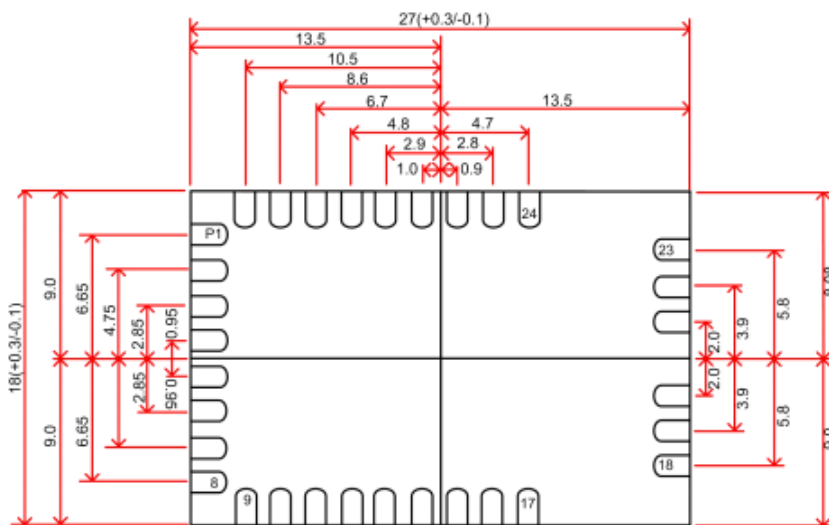

5 Reference Design

5.1 WIFI RF Circuit reference pictures

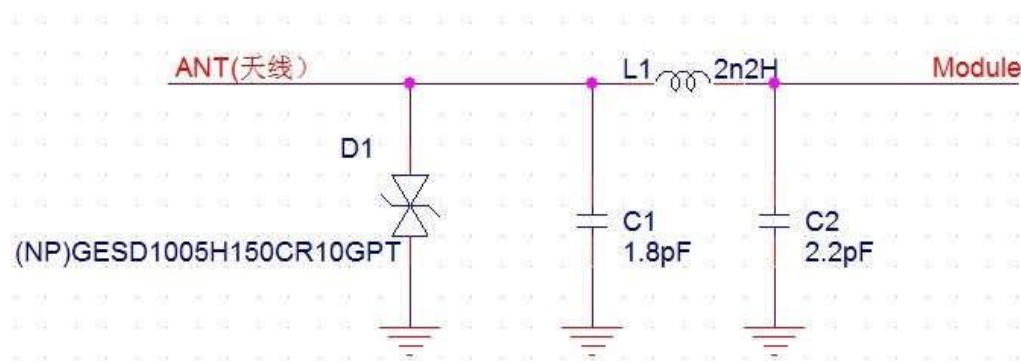

1. Above the dotted box part of the antenna matching is needed, the actual antenna matching electronic parameters shall prevail.
2. For RF part layout to do 50 ohm impedance. can't go on 90° of layout .The line length can't more than 20 mm.

Note: Please be sure to add a TVS tube at the end of the welding antenna to prevent ESD static electricity from damaging the WIFI module (as shown in the reference circuit above).

5.2 USB interface electrical characteristics

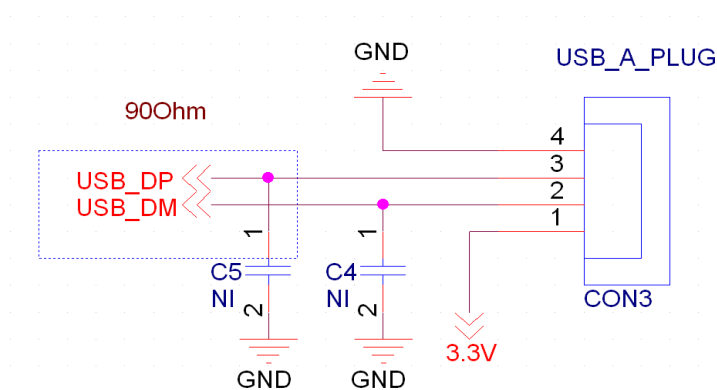

Note:

- 1.USB data cable need to do 90Ohm impedance
- 2.It is recommended to keep a power switch at the input end of the power supply. Each time the card is opened or closed, it can be used for power on and power off. WIFI can be reset, so that there will be no error phenomenon of not opening WIFI.

6.The Key Material List

No.	Parts	Specification	Manufacturer	Note
1	Chipset	RTL8852BU-CG	Realtek Semiconductor Corp	
2	PCB	FT1900BU	Shenzhen xiangyu circuit co., LTD	
3	PCB	FT1900BU	Shenzhen Kexiang Precision Circuit Technology Co., LTD	
4	Crystal oscillator	3225 40MHz \pm 10ppm 10pF -40~85° C SMD 晶威特	hefei jing wei Electronics Co. Ltd.	
5	Crystal oscillator	3225 40MHz \pm 10ppm 10pF -40~85° C SMD 蓝晶	Zhejiang Lanjingxin Microelectronics Co., LTD	

7 Recommended Reflow Profile

Referred to IPC/JEDEC standard.

Peak Temperature : <250° C

Number of Times : \leq 2 times

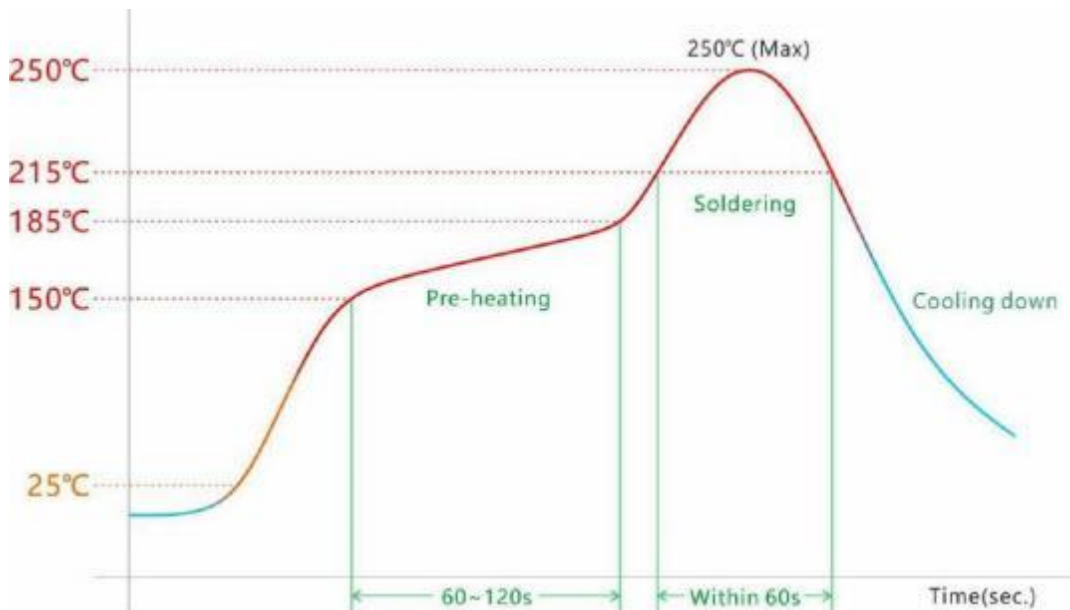

8 Package Information

8.1 Reel

A roll of 2000pcs

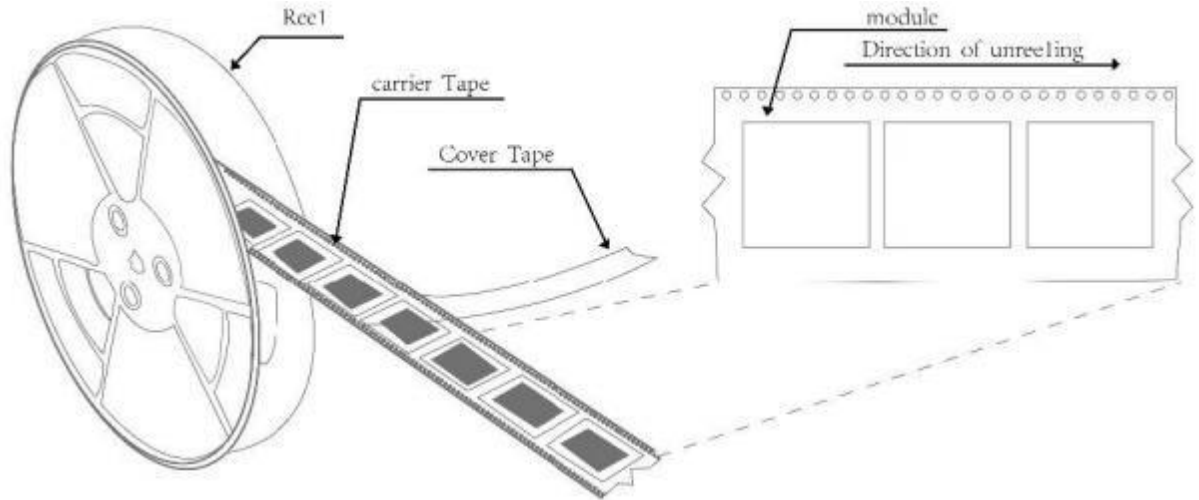

8.2 Carrier Tape Detail

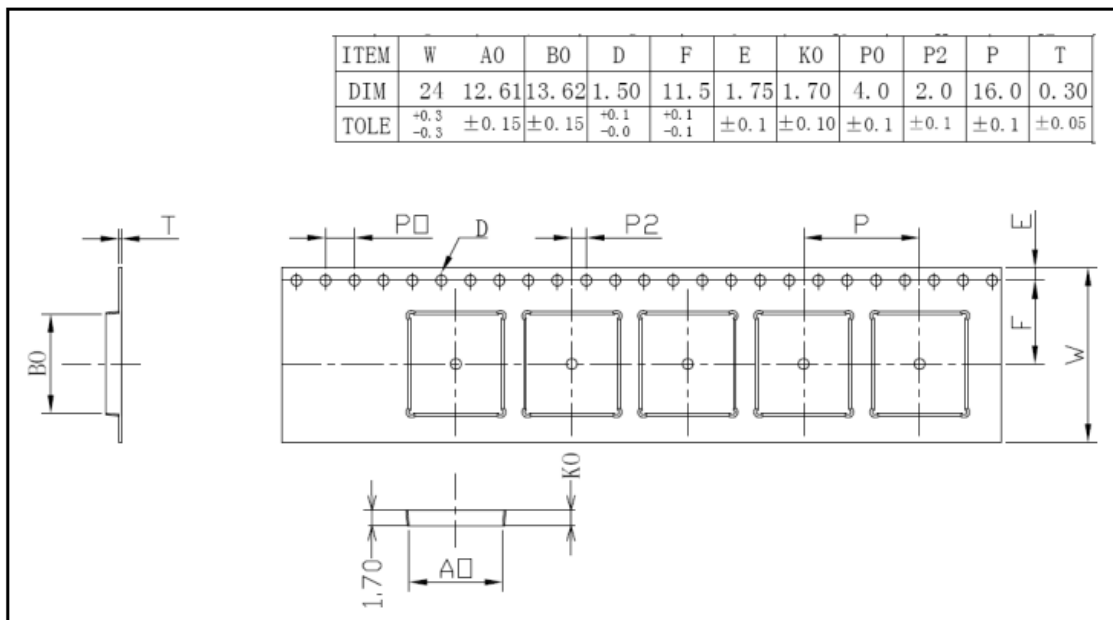

8.3 Packaging Detail

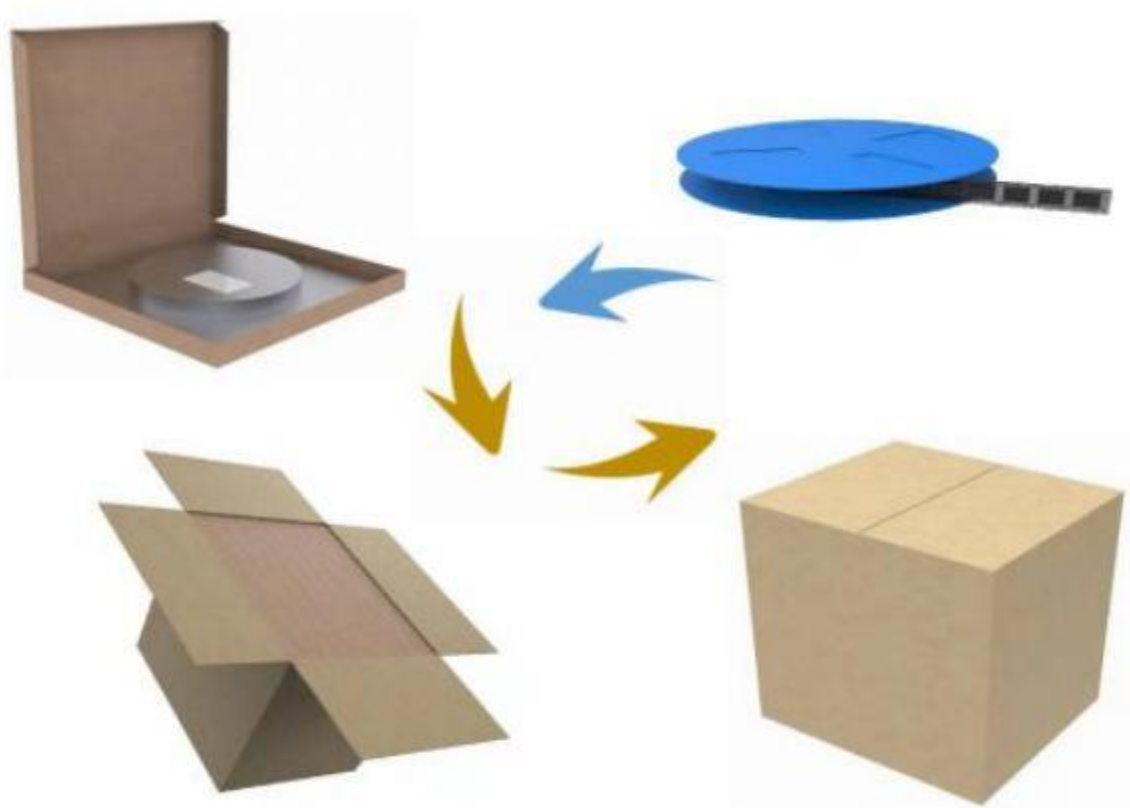

8.4 Moisture sensitivity

The Modules is a Moisture Sensitive Device level 3, in according with standard IPC/JEDEC J-STD-020, take care all the relatives requirements for using this kind of components.

Moreover, the customer has to take care of the following conditions:

- a) Calculated shelf life in sealed bag: 12 months at $<40^{\circ}\text{C}$ and $<90\%$ relative humidity (RH).
- b) Environmental condition during the production: 30°C / 60% RH according to IPC/JEDEC J-STD-033A paragraph 5.
- c) The maximum time between the opening of the sealed bag and the reflow process must be 168 hours if condition
- b) "IPC/JEDEC J-STD-033A paragraph 5.2" is respected
- e) Baking is required if conditions b) or c) are not respected
- f) Baking is required if the humidity indicator inside the bag indicates 10% RH or more